

REV.	REVISION RECORD	BY	DATE
0	ORIGIN	MYX	8.8.2025

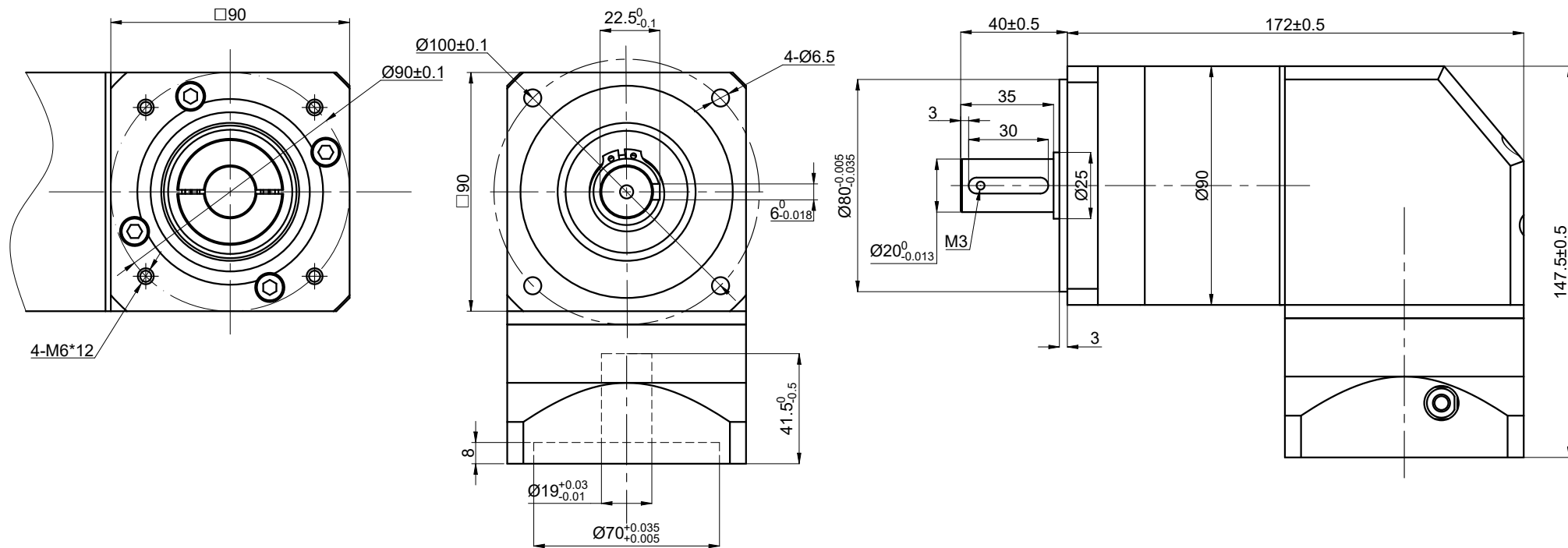

SPECIFICATION	CONNECTION	VALUE
GEAR RATIO		20
EFFICIENCY		94%
BACKLASH@NO-LOAD(arcmin)		<=15
MAX.PERMISSIBLE TORQUE(Nm)[lb-in]		90.00[796.57]
MOMENT PERMISSIBLE TORQUE(Nm)[lb-in]		180.00[1593.13]
SHAFT MAXIMUM AXIAL LOAD(N)		800
SHAFT MAXIMUM RADIAL LOAD(N)		1000
GEARBOX MATCHING MOTOR'S INPUT SHAFT LENGTH (mm)		22~41
RATED INPUT SPEED(RPM)		3000
MAX. INPUT SPEED(RPM)		6000
NOISE(dB)		<=65
WATERPROOF RATING		IP54
LIFE(h)		20000
WORKING TEMPERATURE		-20°C~150°C[-4°F~302°F]

DIMENSIONS ARE IN MILLIMETERS.
 TOLERANCES AS BELOW:
 DECIMALS ANGLES
 X ±0.5 ±2°
 X.X ±0.25
 X.XX ±0.13

THIRD ANGLE PROJECTION		
SIGNATURE		DATE
DRN	MYX	8.8.2025
APVD	LJ	8.8.2025

STEPPERONLINE®

GEARBOX

RTG90-G20

REV.	0	SCALE	1:2	DWG NO.	A4851
------	---	-------	-----	---------	-------