

STEPPERONLINE[®]

iCL Series Integrated Closed Loop Stepper Motor User Manual

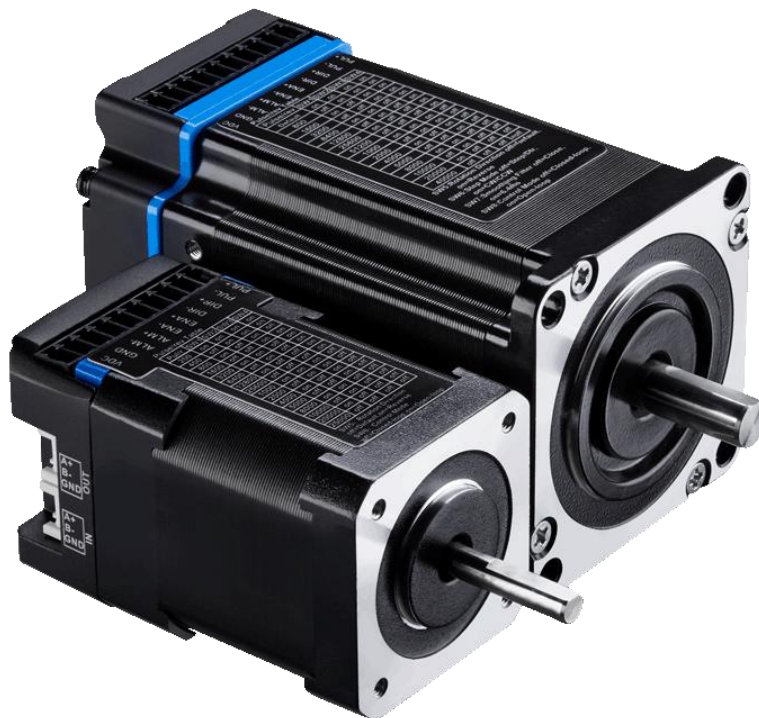

©2023 All Rights Reserved

Address: 15-4, #799 Hushan Road, Jiangning, Nanjing, China

Tel: 0086-2587156578

Web: www.omc-stepperonline.com

Sales: sales@stepperonline.com

Support: technical@stepperonline.com

Notice

Read this manual carefully before any assembling and using. Incorrect handling of products in this manual can result in injury and damage to persons and machinery. Strictly adhere to the technical information regarding installation requirements.

This manual is not for use or disclosure outside of Leadshine except under permission. All rights are reserved. No part of this manual shall be reproduced, stored in retrieval form, or transmitted by any means, electronic, mechanical, photocopying, recording, or otherwise without approval from Leadshine. While every precaution has been taken in the preparation of the book, Leadshine assumes no responsibility for errors or omissions. Neither is any liability assumed for damages resulting from the use of the information contained herein.

This document is proprietary information of Leadshine that is furnished for customer use ONLY. Information in this document is subject to change without notice and does not represent a commitment on the part of Leadshine. Therefore, information contained in this manual may be updated from time-to-time due to product improvements, etc., and may not conform in every respect to former issues.

- ◆ **Thank you for purchasing Leadshine iCL Series Products**
- ◆ **Please read this manual carefully before operating**
- ◆ **Please keep this manual appropriately**

Record of Revisions

Manual Revision	Data	Description of Release
V1.0	02/25/2022	Initial Release
V1.1	10/20/2022	<ul style="list-style-type: none"> ● Modify the description about encoder ● Modify the torque of some models

Table of Content

1 Introduction	1
1.1 Product Introduction	1
1.2 Features	1
1.3 Applications	1
2. Specifications	1
2.1 Electrical Specifications	1
2.2 Environment	2
2.3 Dimensions	2
3. Connections and LED Indication	3
3.1 Connector P1 – Power & Control & Digital Outputs Connector	3
3.1.1 Pin Assignments of P1	3
3.1.2 Connection of Control Signals	3
3.1.3 Connection of ALM Signal	4
3.1.4 Connection of Power Supply	5
3.2 Connector P2 – Tuning Port	5
3.3 LED Light Indication	5
4. DIP Switch Configurations	6
4.1 Microstep Resolution (SW1-SW4)	6
4.2 Other DIP Switch Settings	7
5. Accessories	7
6. Warranty	8

1 Introduction

1.1 Product Introduction

iCL series is stepper motor integrated 14-bit incremental magnetic encoder and drive to solve the loss of step problems in open loop stepper control systems, thus increase system reliability at minimal cost increase. It implements advanced control algorithm of Leadshine based on its tens of years' experience in stepper and servo controls. At very compact size and with all components integrated, the iCL can save mounting space, eliminate encoder connection & motor wiring time, reduce interference, and cut/reduce cable and labor costs.

The iCL series is reliable and affordable and performs excellent in many industrial applications such as CNC, 3D printer, stage equipment, medical, electronics, packaging...etc.

1.2 Features

- No loss of step & no torque reservation & no hunting or overshooting & no tuning for easy setup
- Enhance performance, especially at low speed application (<60RPM)
- Soft-start with no "jump" when powered on
- Low noise and vibration, smooth motion
- Step&direction and CW&CCW control
- 3 digital inputs, 1 optically isolated digital output
- 14-bit single-turn incremental encoder
- RS232 communication for Leadshine software connection
- Over voltage, over current, position following error protections, etc.

1.3 Applications

The iCL series can be adopted in many low to median speed applications such as 3D printer, lab automation instruments, plotters, medical equipment, electronic equipment, small packaging machines, etc.

2. Specifications

2.1 Electrical Specifications

Model	Frame Size	Length (mm)	Holding Torque (N.m)	Weight (Kg)	Command Source		Electrical Parameters		Control Signal				
					PUL& DIR	CW& CCW	Power Voltage (VDC)	Peak Current (A)	Logical Current	Logical Voltage	Max Input Frequency	MIN PUL Width	MIN DIR Setup
iCL42-03	NEMA 17	64	0.3	0.5	✓	x	20-36	0.3 - 3.0	7-16mA	5V	200KHz	2.5µs	5.0µs
iCL42-06		72	0.6	0.9	✓	x	20-36	0.3 - 3.0					
iCL42-08		85	0.8	1.1	✓	x	20-36	0.3 - 3.0					
iCL57-13	NEMA 23	75	1.3	1.0	✓	✓	20-50	0.5 - 4.5					
iCL57-23		96	2.3	1.3	✓	✓	20-50	0.5 - 7.0					
iCLD57-21		89	2.1	1.4	✓	✓	20-50	0.5 - 7.0					
iCLD57-31		109	3.1	1.6	✓	✓	20-50	0.5 - 7.0					
iCL60-30	NEMA 24	109	3.0	1.6	✓	✓	20-50	0.5 - 7.0					
iCL60-35		122	3.5	1.9	✓	✓	20-50	0.5 - 7.0					

2.2 Environment

Cooling	Natural Cooling or Forced Cooling	
Operating Environment	Environment	Avoid dust, oil fog and corrosive gases
	Humidity	40%RH - 90%RH
	Operating Temperature	0°C - 40°C (32°F - 104°F)
	Vibration	10-50Hz / 0.15mm
Storage Temperature	-20°C - 65°C (-4°F - 149°F)	

2.3 Dimensions

(unit: mm [1inch=25.4mm])

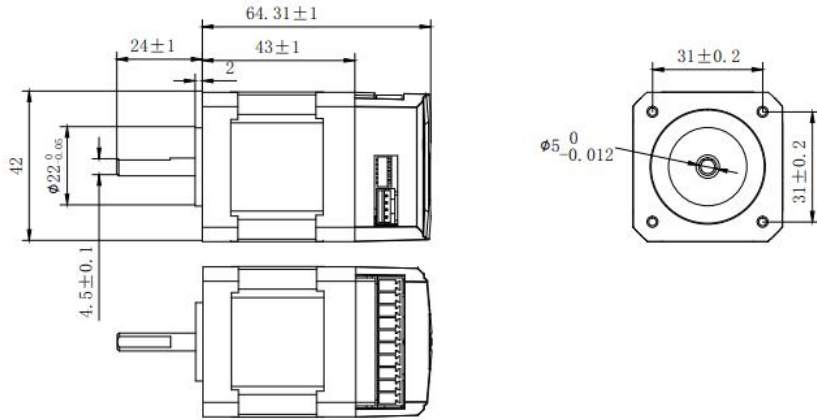

Models	L1 length	L length
iCL42-03	43	64
iCL42-06	51	72
iCL42-08	64	85

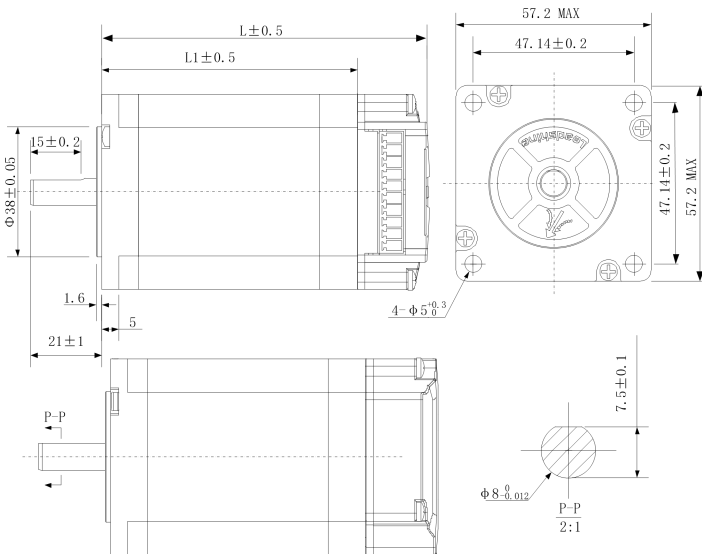

Models	L1 length	L length
iCL57-13	54	75
iCL57-23	75	96
iCLD57-21 ①	68	89
iCLD57-31 ①	88	109

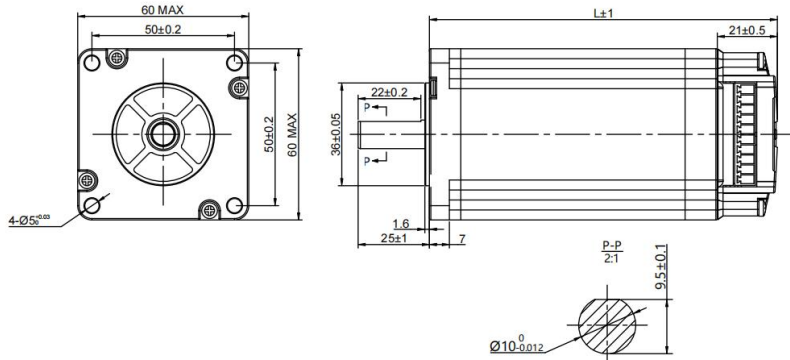

Models	L1 length	L length
iCL60-30 ②	88	109
iCL60-35 ③	101	122

- Note: ① Frame size is 60mm.
 ② Frame size is 60mm, center diameter is 36mm.
 ③ Frame size is 60mm, center diameter is 36mm, shaft diameter is 10mm

Figure 1: Mechanical specifications

3. Connections and LED Indication



Figure 2: iCL series connectors

3.1 Connector P1 – Power & Control & Digital Outputs Connector

3.1.1 Pin Assignments of P1

The P1 connector in Figure 2 contains connections for control signals and 2 digital output. See the following table for details.

PIN	I/O	Details
VCC	I	Power supply positive connection. 20-36VDC power supply voltage
GND	I	Power supply ground connection.
ALM-	O	Alarm: An OC output signal. It takes a sinking or sourcing at 5-24V@30mA
ALM+	O	
ENA-	I	Enable Signals: Optional, not connected by default. (1) Effective high level is 4.5-5V; Effective low level is 0-0.5V connection (2) ENA signal requires advance DIR signal minimum 200ms in single pulse mode
ENA+	I	
DIR-	I	Pulse and Direction Connection: (1) Optically isolated, high level 4.5-5V, low voltage 0-0.5V. (2) Max 200 KHz input frequency. (3) The width of PUL signal is at least 2.5µs, duty cycle is recommended 50%. (4) Single pulse (step & direction), iCL-23xx and iCL-24xx support double pulse (CW&CCW), while iCL-17xx do not support. (5) DIR signal requires advance PUL signal minimum 5 µs.
DIR+	I	
PUL-	I	
PUL+	I	

Notes:

(1) Shielding control signal wires is suggested.

(2) To avoid/reduce interference, do not tie control signal cables with the power cables/wires together.

3.1.2 Connection of Control Signals

The iCL series motor can accept differential and single-ended control signal inputs (open-collector and PNP output). It has 3 optically isolated control inputs, PUL, DIR, and ENA. Refer to the following two figures for connections of PNP and NPN signals.

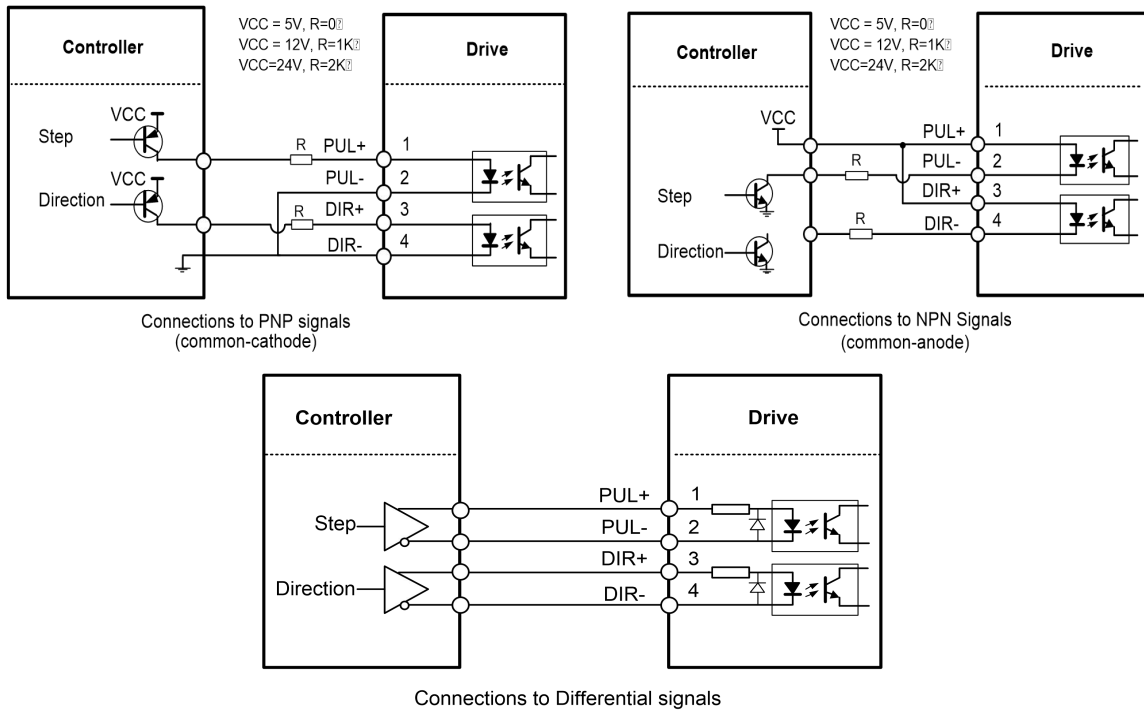

Figure 3: Control Signals Connection

- Notes: (1) ENA signal is not connected as default;
- (2) If the logic voltage is not 5V, it needs to connect resistors.

3.1.3 Connection of ALM Signal

Alarm output is the default configuration. This output signals a fault condition including over-voltage, over-current, or position following error. This output can be used to drive devices such as a relay, a LED, etc., or as an input signal to electronic devices like a PLC.

For example, in a multi-axis system like a CNC machine when one of the axes fails such a fault output signal can be feedback to the motion controller for a followed action (e.g., auto machine shutdown, auto error clearing, etc.).

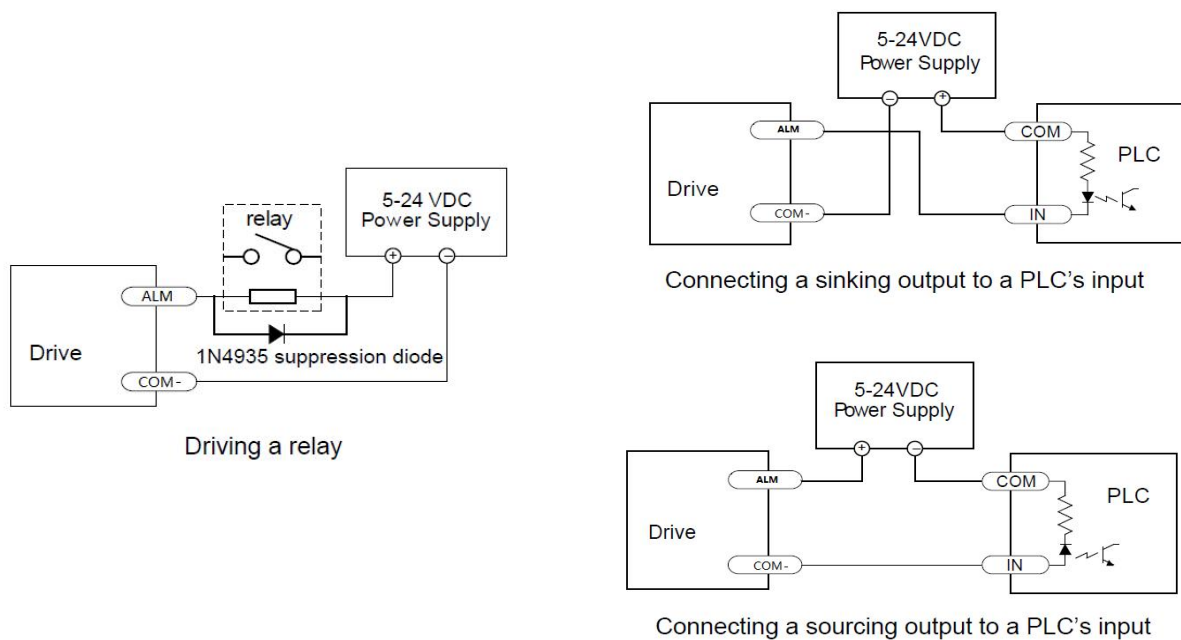

Figure 4: ALM Signals Connection

3.1.4 Connection of Power Supply

Pin Name	Details
+VDC	Power supply positive connection. iCL42-xx:20-36VDC iCL57-xx and iCL60-xx: 20-50 VDC
GND	Power supply ground connection.

Notes: It is recommended that power voltage of all integrated motors are 24VDC, otherwise if the motor is too hot, it is easy to transfer heat to the drive, thus damaging the drive.

3.2 Connector P2 – Tuning Port

The P2 connector in Figure 2 is a communication port for Leadshine software connection. It is just used to modify parameters, not for equipment control because neither precision nor stability is sufficient. If you need a Modbus-RS485 control, please use a Leadshine iCL-RS series integrated stepper motor. The interface definition is as follows:

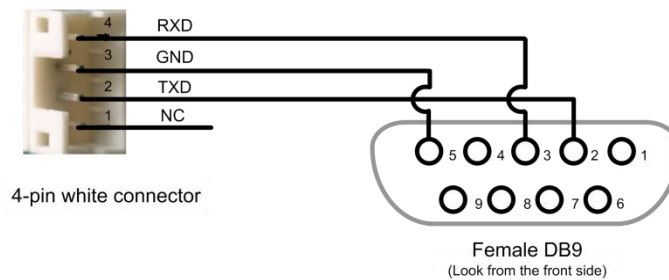

Figure5: RS232 Tuning Port

3.3 LED Light Indication

There are two LED lights for iCL series motor, one is red and another is green. The GREEN one is the power indicator which will be always on generally. The RED one is a protection indicator. It is off always when a iCL42-xx operates normally, but will flash 1, 2 or 7 times in a 5-second period when error protection is enabled. Different number of flashes indicates different protection types.

Blink time(s)	Sequence wave of red LED	Description	Trouble shooting
1		Over-current	Turn off the power immediately. a) Check wiring is short-circuited or not; b) Check motor is short-circuited or not.
2		Over-voltage	Turn off the power immediately. a) Check if the power voltage is higher than 90VDC
7		Position following error	a) The value of position following error is set too small. b) Motor torque is not enough, or motor speed is too high.
Always	-	PCB board is burned out	Contact after-sale a) Power supply connection is wrong

When above protections are active, the motor shaft will be free and the red LED blinks. Reset the drive by repowering it to make it function properly after removing above problems.

4. DIP Switch Configurations

The iCL series has a row of DIP switches, but the iCL42-xx and iCL57-xx DIP switches are a bit different, as follows

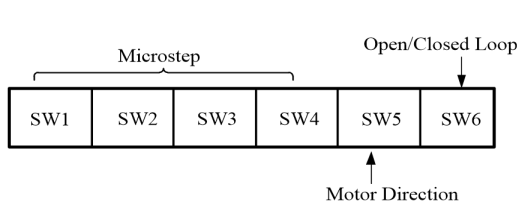

iCL42-xx

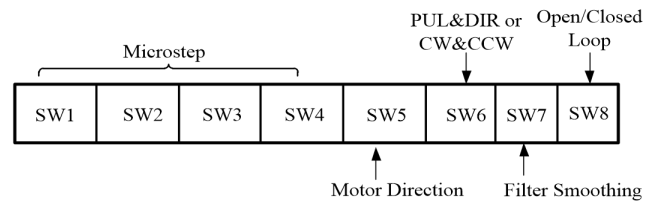

iCL57-xx and iCL60-xx

4.1 Microstep Resolution (SW1-SW4)

- For iCL42-xx Series

Microstep resolution is set by SW1, 2, 3, 4 of the DIP switches as shown in the following table:

Steps/Revolution	SW1	SW2	SW3	SW4
200 (Default)	on	on	on	on
400	off	on	on	on
800	on	off	on	on
1600	off	off	on	on
3200	on	on	off	on
6400	off	on	off	on
12800	on	off	off	on
25600	off	off	off	on
1000	on	on	on	off
2000	off	on	on	off
4000	on	off	on	off
5000	off	off	on	off
8000	on	on	off	off
10000	off	on	off	off
20000	on	off	off	off
25000	off	off	off	off

- For iCL57-xx and iCL60-xx Series

Steps/Revolution	SW1	SW2	SW3	SW4
400 (Default)	on	on	on	on
800	off	on	on	on
1600	on	off	on	on
3200	off	off	on	on
6400	on	on	off	on
12800	off	on	off	on
25600	on	off	off	on
51200	off	off	off	on
1000	on	on	on	off

2000	off	on	on	off
4000	on	off	on	off
5000	off	off	on	off
8000	on	on	off	off
10000	off	on	off	off
20000	on	off	off	off
40000	off	off	off	off

4.2 Other DIP Switch Settings

- For iCL42-xx Series (SW5-SW6)

	Function	On	Off
SW5	Default Direction	CW (clockwise)	CCW (counterclockwise)
SW6	Closed/Open loop	Open Loop	Closed Loop

- For iCL57-xx and iCL60-xx Series (SW5-SW8)

	Function	On	Off
SW5	Default Direction	CW (clockwise)	CCW (counterclockwise)
SW6	Pulse Mode	CW&CCW	PUL&DIR
SW7	Smoothing Time	Enable	Disable
SW8	Closed/Open Loop	Open Loop	Closed Loop

5. Accessories

If you plan to use the Leadshine software, contact your supplier or Leadshine to purchase the RS232 cable with part number [CABLE-PC-1](#) for V2.0 version motor (CABLE-PC-ICL42 for V1.0 version). In the case of using USB to RS232 conversion, contact your supplier or Leadshine for such a cable with part number [C006](#) which has been verified working fine.



[CABLE-PC-1](#)
(RS232 tuning cable)



[C006](#)
(USB to RS232 Conversion Cable)

6. Warranty

Twelve Month Warranty

Leadshine Technology Co., Ltd. warrants its products against defects in materials and workmanship for a period of 12 months from shipment out of factory. During the warranty period, Leadshine will either, at its option, repair or replace products which proved to be defective.

Exclusions

The above warranty does not extend to any product damaged by reasons of improper or inadequate handlings by customer, improper or inadequate customer wirings, unauthorized modification or misuse, or operation beyond the electrical specifications of the product and/or operation beyond environmental specifications for the product.

Obtaining Warranty Service

To obtain warranty service, please contact your seller to obtain a returned material authorization number (RMA) before returning product for service.

Shipping Failed Products

If your product fail during the warranty period, please contact your seller for how and where to ship the failed product for warranty or repair services first, you can also e-mail customer service at technical@omc-stepperonline.com to obtain a returned material authorization number (RMA) before returning product for service. Please include a written description of the problem along with contact name and address.