

CUSTOMER'S MODEL: NO MODEL  
 END COVER COLOR: BLACK

REV.	REVISION RECORD	BY	DATE
0	ORIGIN	HW	7.2.2024

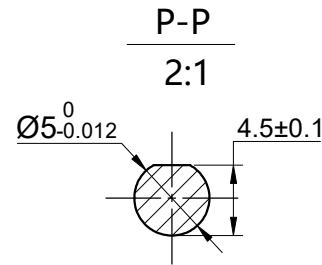
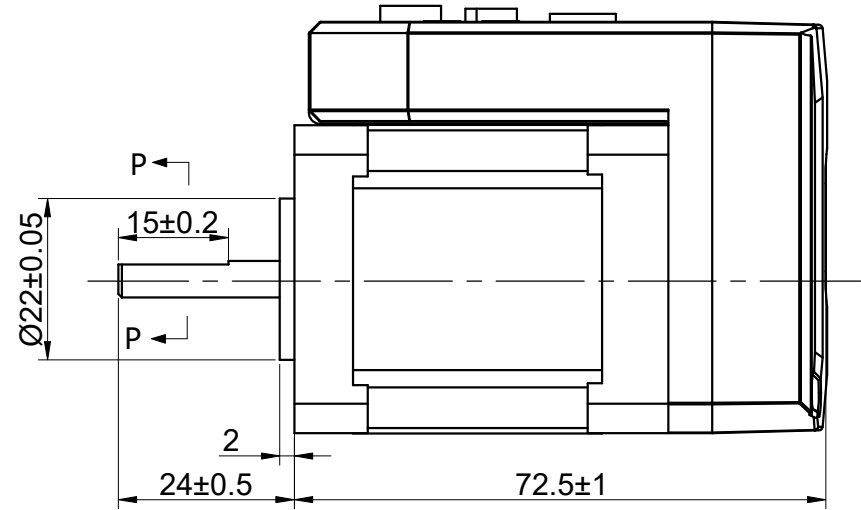
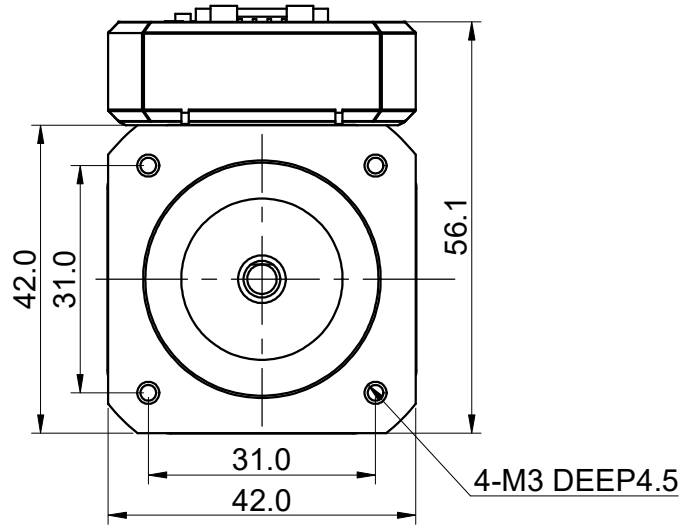

CONNECTION	BIPOLAR
SPECIFICATION	
POWER VOLTAGE(V)	20-36
PEAK CURRENT(A)	0.3-3.0
INPUT LOGICAL VOLTAGE(V)	12-24
OUTPUT CAPABILITY	24V@100mA
HOLDING TORQUE(Nm)[lb-in]	0.40[3.54]
STEP ANGLE(°)	1.80
STEP ACCURACY(NON-ACCUM)	±5.00%
MAX. BAUD RATE	115200
WEIGHT(Kg)[lb]	1.00[2.20]
AMBIENT TEMPERATURE	0°C~50°C[32°F~122°F]
INSULATION CLASS	B 130°C[266°F]
TEMPERATURE RISE	MAX.80°C

FULL STEP 2 PHASE-Ex.,WHEN FACING MOUNTING END (X)					DIMENSIONS ARE IN MILLIMETERS.	
STEP	A+	B+	A-	B-	CCW	TOLERANCES AS BELOW:
1	+	+	-	-	↓ CW ↑ CCW	DECIMALS      ANGLES
2	-	+	+	-		X      ±0.5      ±2°
3	-	-	+	+		X.X    ±0.25
4	+	-	-	+		X.XX   ±0.13
					THIRD ANGLE PROJECTION	

**STEPPERONLINE®**

**INTEGRATED STEPPER MOTOR**

**iCL42-RS06**

REV.	0	SCALE	1:1	DWG NO.	A3448
------	---	-------	-----	---------	-------

THIS DOCUMENT SHALL NOT BE REPRODUCED NOR SHALL THE INFORMATION CONTAINED HEREIN BE USED BY OR DISCLOSED TO OTHERS UNLESS EXPRESSLY AUTHORIZED IN BY WRITING STEPPERONLINE.			SIGNATURE	DATE
DRN	HW			7.2.2024
APVD	ZPJ			7.5.2024