

CUSTOMER'S MODEL: NO MODEL
 END COVER COLOR: BLACK

| REV. | REVISION RECORD | BY | DATE |
|------|-----------------|-----|-----------|
| 0 | ORIGIN | LDJ | 7.31.2025 |

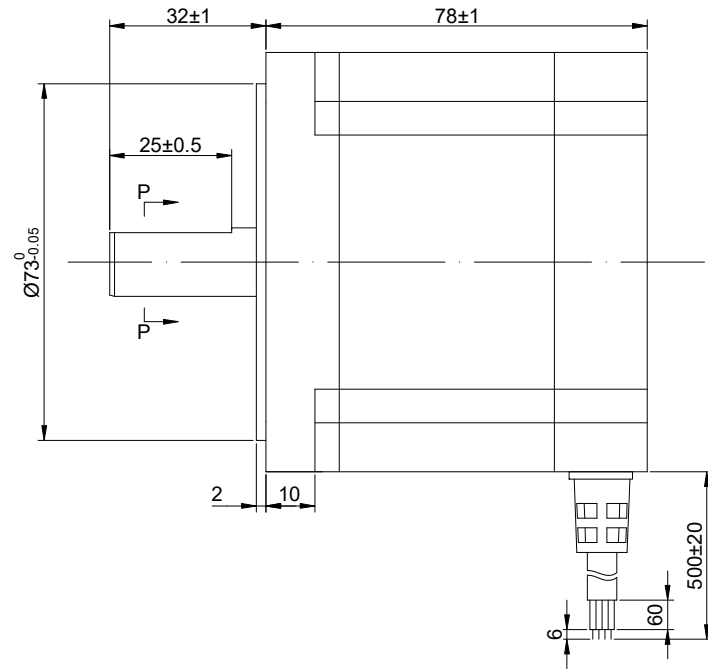
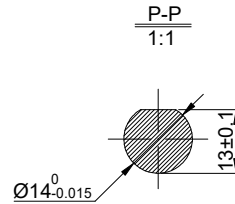
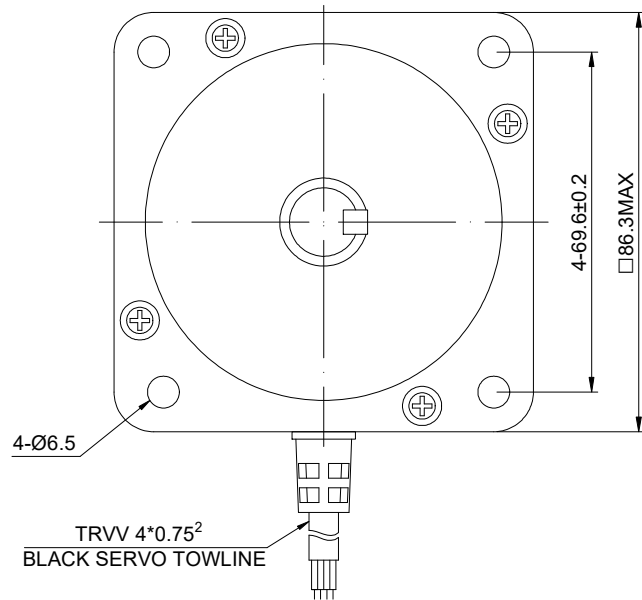

| MOTOR CONNECTION | | | |
|------------------|---------|-------|---------|
| PIN NO | BIPOLAR | LEADS | WINDING |
| 1 | A+ | BLK | |
| 2 | A- | GRN | |
| 3 | B+ | RED | |
| 4 | B- | BLU | |

| SPECIFICATION | CONNECTION | BIPOLAR |
|-----------------------------|------------|------------------------|
| AMPS/PHASE | | 6.00 |
| RESISTANCE/PHASE(Ohms)@25°C | | 0.42±10% |
| INDUCTANCE/PHASE(mH)@1KHz | | 3.80±20% |
| HOLDING TORQUE(Nm)[lb-in] | | 4.80[42.53] |
| STEP ANGLE(°) | | 1.80 |
| STEP ACCURACY(NON-ACCUM) | | ±5.00% |
| ROTOR INERTIA(g-cm²) | | 1400 |
| WEIGHT(Kg) | | - |
| AMBIENT TEMPERATURE | | -10°C~50°C[14°F~122°F] |
| INSULATION CLASS | | B 130°C[266°F] |
| TEMPERATURE RISE | | MAX.80°C |

COMMENT:
 1.TMBF 6000h OR MORE @ 24V/300RPM
 2.INSULATION RESISTANCE (NORMAL TEMPERATURE AND HUMIDITY): 100 Mohm
 3.DIELECTRIC STRENGTH 500VAC FOR 1MIN.(BETWEEN THE MOTOR COILS AND THE MOTOR CASE)

| FULL STEP 2 PHASE-EX.,WHEN FACING MOUNTING END (X) | | | | | CCW | CW | DIMENSIONS ARE IN MILLIMETERS. TOLERANCES AS BELOW: DECIMALS ANGLES X ±0.5 ±2° X.X ±0.25 X.XX ±0.13 |
|--|----|----|----|----|-----|----|--|
| STEP | A+ | B+ | A- | B- | | | |
| 1 | + | + | - | - | | | |
| 2 | - | + | + | - | | | |
| 3 | - | - | + | + | | | |
| 4 | + | - | - | + | | | |

THIS DOCUMENT SHALL NOT BE REPRODUCED NOR SHALL THE INFORMATION CONTAINED HEREIN BE USED BY OR DISCLOSED TO OTHERS UNLESS EXPRESSLY AUTHORIZED IN BY WRITING STEPPERONLINE.

| SIGNATURE | | DATE |
|-----------|-----|-----------|
| DRN | LDJ | 7.31.2025 |
| APVD | MYX | 8.1.2025 |

STEPPERONLINE®

STEPPER MOTOR

34HS30-6004S

| | | | | | |
|------|---|-------|-----|---------|-------|
| REV. | 0 | SCALE | 2:3 | DWG NO. | A1500 |
|------|---|-------|-----|---------|-------|