

User Manual
3DM580S

3-Phase Digital Microstep Drive



Revision 1.0

©2021 Leadshine Technology Co., Ltd.

Important Notice

Read this manual carefully before any assembling and using. Incorrect handling of products in this manual can result in injury and damage to persons and machinery. Strictly adhere to the technical information regarding installation requirements.

This manual is not for use or disclosure outside of Leadshine except under permission. All rights are reserved. No part of this manual shall be reproduced, stored in retrieval form, or transmitted by any means, electronic, mechanical, photocopying, recording, or otherwise without approval from Leadshine. While every precaution has been taken in the preparation of the book, Leadshine assumes no responsibility for errors or omissions. Neither is any liability assumed for damages resulting from the use of the information contained herein.

This document is proprietary information of Leadshine that is furnished for customer use ONLY. Information in this document is subject to change without notice and does not represent a commitment on the part of Leadshine. Therefore, information contained in this manual may be updated from time-to-time due to product improvements, etc., and may not conform in every respect to former issues.

Record of Revisions

Revision	Date	Description of Release
1.0	Sept, 2021	Initial Version.

Table of Contents

1. Introduction	1
1.1 Features	1
1.2 Applications	1
2.Specifications	1
2.1 Electrical Specifications	1
2.2 Environment	2
2.3 Mechanical Specifications	2
2.4 Elimination of Heat	2
3. Connection Pin Assignments and LED Indication	3
3.1 P1& P2 - Control & Fault Connector	3
3.2 P3 - Power and Motor Connector	4
3.3 P4 - Tuning Port	4
3.4 Status LED (Protection Functions)	4
4. Control Signal and Fault Output Wiring	5
4.1 Control Signal Connection	5
4.2 Fault Output Connection	5
4.3 Sequence Chart of Control Signals	6
4.4 Typical Connection	6
5. DIP Switch Configurations	7
5.1 Output Current (SW1-SW4)	7
5.2 Standstill Current Setting (SW5)	8
5.3 Microstep Resolution (SW6-SW8)	8
5.4 Smoothing Filter Table (SW9-SW10)	8
5.5 Motion Mode Configuration (SW11)	9
5.6 Alarm Output Configuration (SW12)	9
5.7 Activated Pulse Edge Configuration (SW13)	9
5.8 Pulse Mode Configuration (SW14)	9
5.9 Shaft Lock in Non-enabled State (SW15)	9
5.10 Self-Test Configuration (SW16)	9
6. Power Supply Selection	9
6.1 Regulated or Unregulated Power Supply	10
6.2 Power Supply Sharing	10
6.3 Selecting Supply Voltage	10
7. Motor Selection	11
8. Troubleshooting	11
9. Warranty	12

1. Introduction

The 3DM580S is Leadshine newest digital stepper drive based on an advanced control algorithm. It brings a unique level of system smoothness, providing optimum torque and nulls mid-range instability. Motor self-test and parameter auto-setup technology offers optimum responses with different motors and easy-to-use. The driven motors can run with much smaller noise, lower heating, smoother movement than most of the drives in the markets. Its unique features make the 3DM580S an ideal solution for applications that require low-speed smoothness.

1.1 Features

- Step & direction (PUL/DIR) or CW/CCW (double pulse) control
- Suggested supply voltage 20-50 VDC
- 500KHz max pulse input frequency in dutycycle 50%
- 8 microstep resolutions of 200-10,000 via DIP switches, or 200-51,200 via software (increase by 100)
- 16 output current settings of 2.1 -8.0A via DIP Switches, or 0.5-8.0A via software (increase by 0.1)
- Configurable control command smoothing for reducing motor vibration
- Idle current reduction to 50% or 90% selection via SW5
- Convenient self-test for easy diagnosis
- Two motion modes of low-speed smooth and high-speed large torque
- Anti-Resonance for optimal torque, extra smooth motion, low motor heating and noise
- Soft-start with no “jump” when powered on
- Fault output
- Over-voltage, over-current protections
- CE certified and RoHS compliant

1.2 Applications

Suitable for a wide range of Stepper motors, from NEMA frame size 17 to 34. It can be used in various kinds of machines, such as laser cutters, laser markers, high precision X-Y tables, labeling machines, and so on. Its unique features make the 3DM580S an ideal solution for applications that require both low-speed smoothness and high speed performances.

2. Specifications

2.1 Electrical Specifications

Parameters	Min	Typical	Max	Unit
Output Current	0.5	-	8.0 (5.7 RMS)	A
Supply Voltage	20	24 - 48	74	VDC
Logic signal current	7	10	16	mA
Pulse input frequency	0	-	500	kHz
Minimal pulse width	1	-	-	μs
Minimal direction setup	5	-	-	μs
Isolation resistance	500	-	-	MΩ

2.2 Environment

Cooling	Natural Cooling or Forced cooling	
Operating Environment	Environment	Avoid dust, oil fog and corrosive gases
	Ambient Temperature	0 — 65°C (32 - 149°F)
	Humidity	40 — 90%RH
	Operating Temperature	0 — 50°C (32 - 122°F)
	Vibration	10-50Hz / 0.15mm
Storage Temperature	-20°C — 65°C (-4°F - 149°F)	
Weight	Approx. 250g (8.8 oz)	

2.3 Mechanical Specifications

(unit: mm [inch], 1 inch = 25.4 mm)

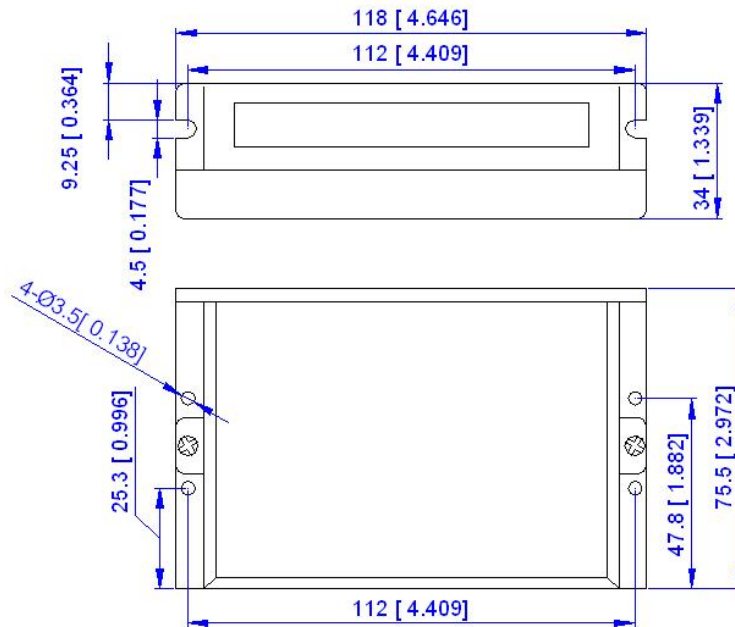

Figure 1 Mechanical specifications

* Side mounting recommended for better heat dissipation

2.4 Elimination of Heat

- Drive's reliable working temperature should be <70°C(158°F), and motor working temperature should be <80°C(176°F);
- It is recommended to use automatic idle-current mode, namely current automatically reduce to 50% when motor stops, so as to reduce Drive heating and motor heating;
- It is recommended to mount the Drive vertically to maximize heat sink area. Use forced cooling method to cool the system if necessary.

3. Connection Pin Assignments and LED Indication

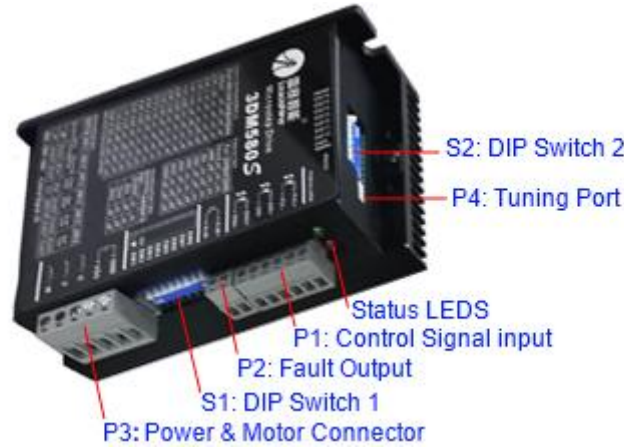

Figure 2 Connectors, DIP switches, and LED locations

The 3DM580S has 4 connectors P1, P2, P3 and P4, 2 DIP switches S1 and S2. P1 is for control signal connections, P2 is for fault output, P3 is for power and motor connection, P4 is for fine tuning.

3.1 P1& P2 - Control & Fault Connector Configurations

Pin Name	I/O	Details
PUL+	I	<u>Pulse signal:</u> (1) . In single pulse (pulse & direction) control mode, this input represents pulse signal. A pulse signal is active at the rising or falling voltage edge (set by DIP switch SW13). (2) . In double-pulse (CW/CCW) control mode (set by DIP switch SW14), this signal input represents clockwise (CW) pulse, and is active at both high voltage level and low voltage level. (3) . 3.5-5V for voltage HIGH, 0-0.5V for voltage LOW (same for DIR signals). (4) . Pulse width should be set to 1μs or longer. (5) . Series connect resistors 1KΩ or 2KΩ for current-limiting when +12V or +24V respectively. The same as DIR and ENA signals.
PUL-	I	
DIR+	I	<u>Direction signal:</u> (1) . In single pulse (step & direction) control mode, this signal's low and high voltage levels represent the two directions of motor rotation (e.g. clockwise and counterclockwise). (2) . In double-pulse (CW & CCW) control mode, this signal represents counterclockwise (CCW) rotation. It is active at both voltage high level and low level. (3) . Minimal DIR signal setup time should be at least 5μs.
DIR-	I	
ENA+	I	<u>Enable signal:</u> (1) . This signal is used for enabling/disabling the drive. High voltage level of 3.5-5VDC (NPN control signal) for enabling the drive and low voltage level of 0-0.5VDC for disabling the drive. PNP and Differential control signals are on the contrary, namely Low level for enabling. (2) . ENA signal requires advance DIR signal minimum 500ms in single pulse mode. (3) . By default this signal is left UNCONNECTED & ENABLED .
ENA-	I	

ALM+	O	<u>Configurable Digital Output Signal:</u> A configurable OC output signal. It takes a sinking or sourcing 20mA current at 5-24V.
ALM-	O	

Notes: (1) Shield cables are required for P1; (2) Do not tie P1 cables and P3 cables together.

3.2 P3 - Power and Motor Connector

Pin Name	Description
GND	Connect to power supply ground connection
+Vdc	Connect to power supply positive connection. Suggest 24-48VDC, considering voltage fluctuation and EMF voltage.
U	Motor phase U
V	Motor phase V
W	Motor phase W

3.3 P4 - Tuning Port

3DM580S has a tuning port with RS232 to modify the drive parameters, it's only for tuning, not for equipment control because neither precision nor stability is sufficient. The interface definition is as follows:

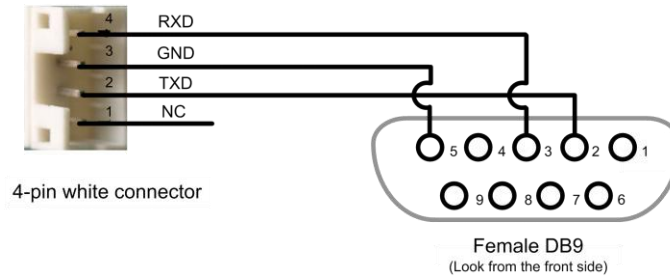
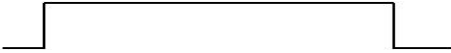

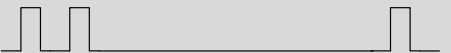

Figure 3 Tuning Port

3.4 Status LED (Protection Functions)

There are two LED lights for 3DM580S. The GREEN one is the power indicator which should be always on in normal circumstance. The RED one is a drive status indication light, which will be OFF while working normally but ON and flash 1 or 2 times in a 3-second period in the case of enabled over-current or over-voltage protection.

Priority	Time(s) of Blink	Sequence wave of red LED	Description
1 st	Always on		The drive was short-circuited or burned out.
1 st	1		Over-current protection activated when peak current exceeds the limit.
2 nd	2		Over-voltage protection activated when drive working voltage is greater than 90VDC

4. Control Signal and Fault Output Wiring

4.1 Control Signal Connection

The 3DM580S can accept differential and single-ended control signal inputs (open-collector and PNP output). A 3DM580S has 3 optically isolated control inputs, PUL, DIR, and ENA. Refer to the following two figures for connections of open-collector and PNP signals.

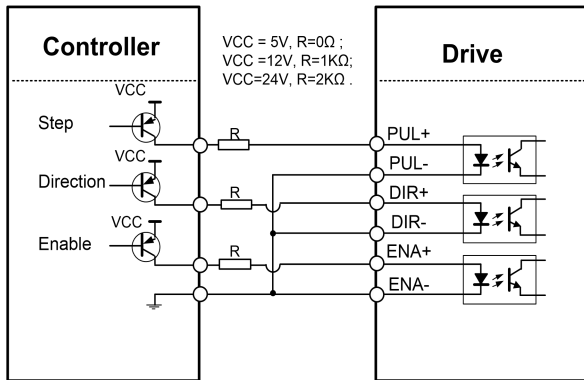

Figure 4-1 Connections to PNP signals (Common-cathode)

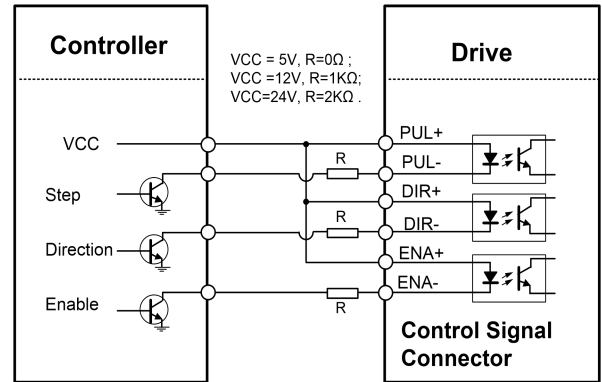

Figure 4-2 Connections to open-collector signals (Common-anode)

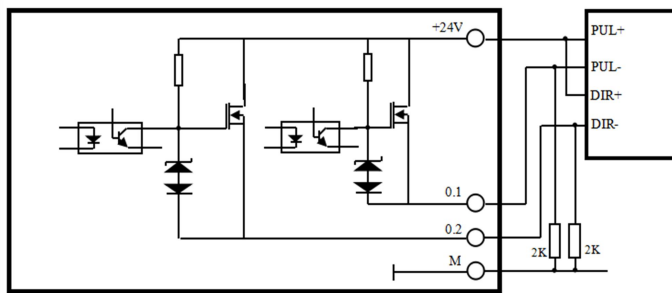

Figure 4-3 Connections to Siemens PLC

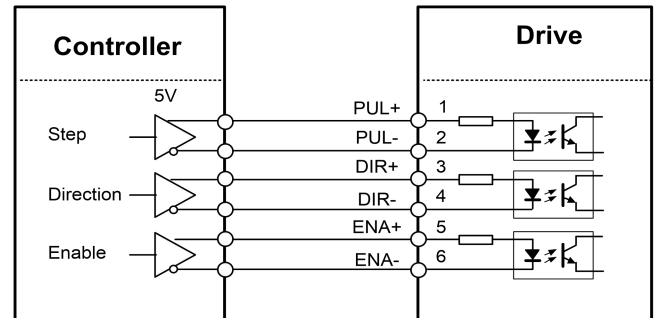
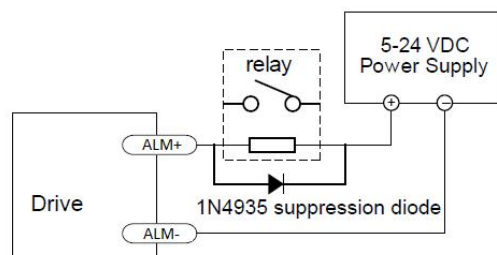

Figure 4-4 Connections to differential signals

4.2 Fault Output Connection

When over voltage or over current protection happens, 3DM580S red status LED light will blink and the impedance state between ALM+ and ALM- will change (from low to high or high to low depending on configuration) and can thus be detected. Fault output connection is optional, and it can be connected either in sinking or sourcing.



Driving a relay

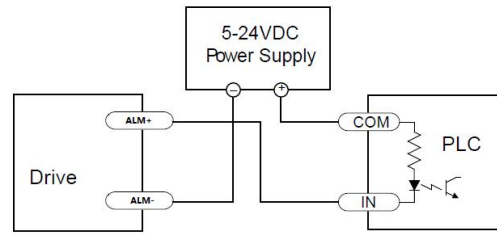

Connecting a sinking output to a PLC's input

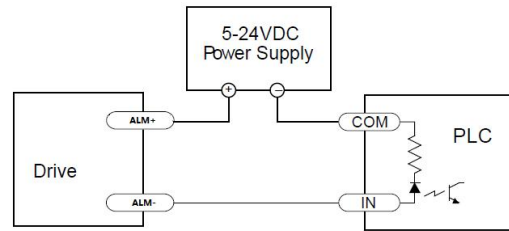

Connecting a sourcing output to a PLC's input

Figure 5 Fault output connections

4.3 Sequence Chart of Control Signals

In order to avoid some fault operations and deviations, PUL, DIR and ENA should abide by some rules, shown as following diagram:

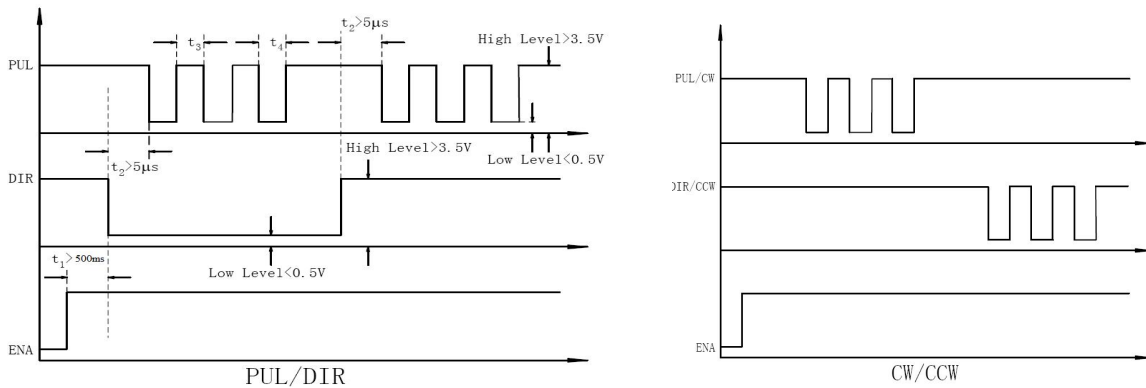
Figure 6 Sequence chart of control signals

Remark:

- (1) t_1 : ENA must be ahead of DIR by at least 500ms. Usually, ENA+ and ENA- are NC (no connected).
- (2) t_2 : DIR must be ahead of PUL effective edge by 5 μ s to ensure correct direction.
- (3) t_3 : Pulse width not less than 1 μ s, these widths are based on a 50% duty cycle. If it is greater or less than 50%, the width time is required to be wider.

4.4 Typical Connection

- In order to improve anti-interference performance of the Drive, it is recommended to use twisted pair shield cable.
- To prevent noise incurred in PUL/DIR signal, pulse/direction signal wires and motor wires should not be tied up together. It is better to separate them by at least 10 cm, otherwise the disturbing signals generated by motor will easily disturb pulse direction signals, causing motor position error, system instability and other failures.

- If a power supply serves several Drives, separately connecting the Drives is recommended instead of daisy-chaining.
- It is prohibited to pull and plug connector P3 while the drive is powered ON, because there is high current flowing through motor coils (even when motor is at standstill). Pulling or plugging connector P3 with power on will cause extremely high back-EMF voltage surge, which may damage the Drive.
- It is strictly prohibited to add tin to the wire head to access the terminal, otherwise the contact resistance may become large and overheating damage to the terminal.
- The wire head should not be exposed outside the terminal to prevent accidental short circuit and damage to the drive.

5. DIP Switch Configurations

The 3DM580S has two 8-bit DIP switches. “Default” means that parameters can be modified by Leadshine PC software. The first 8-bit is located on the side (DIP switch selector 1 in Figure 2) and used to configure settings of micro step resolution, output current, and motor standstill current as shown below,

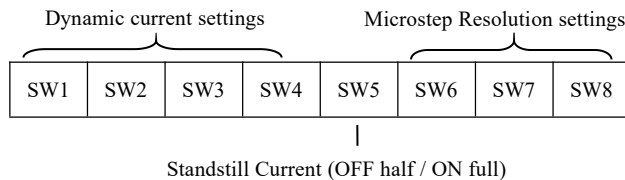

5.1 Output Current (SW1-SW4)

The 3DM580S has 8 output current settings which can be configured through DIP switch SW1, SW2, SW3 and SW4.

For a given stepper motor, as normal setting the output current to 1.4 times of motor phase current, will make it output larger torque, but at the same time cause more heating for both the motor and drive. Therefore, it is suggested to set a output current (peak of sinusoidal) to no more than 1.2 times the stepper motor’s (for 4-lead motor) phase current to prevent overheating .

The SW1, SW2 and SW3 are used to set the dynamic current. Select a setting closest to your motor’s required current. When they are set to **OFF, OFF, OFF, OFF**, the output current can be set by Leadshine PC software.

Peak Current	RMS Current	SW1	SW2	SW3	SW4
2.1A (Default)	1.5A	OFF	OFF	OFF	OFF
2.5A	1.8A	ON	OFF	OFF	OFF
2.9A	2.1A	OFF	ON	OFF	OFF
3.2A	2.3A	ON	ON	OFF	OFF
3.6A	2.6A	OFF	OFF	ON	OFF
4.0A	2.9A	ON	OFF	ON	OFF
4.5A	3.2A	OFF	ON	ON	OFF
4.9A	3.5A	ON	ON	ON	OFF
5.3A	3.8A	OFF	OFF	OFF	ON
5.7A	4.1A	ON	OFF	OFF	ON
6.2A	4.4A	OFF	ON	OFF	ON
6.4A	4.6A	ON	ON	OFF	ON

6.9A	4.9A	OFF	OFF	ON	ON
7.3A	5.2A	ON	OFF	ON	ON
7.7A	5.5A	OFF	ON	ON	ON
8.0A	5.7A	ON	ON	ON	ON

5.2 Standstill Current Setting (SW5)

The SW5 of an 3DM580S is used to set output current percentage when motor is standstill. Idle current percentage will be set to 50% at OFF position, and 90% at ON position. When the driven stepper motor is idle (no movement) for 0.4 second, the output current of 3DM580S will be automatically reduced to the configured percentage.

5.3 Microstep Resolution (SW6-SW8)

Each 3DM580S has 8 micro step settings which can be configured through DIP switch SW6, SW7 and SW8. The driver has an internal calculator to achieve 200 steps to make the 3-phase stepper motor turn one turn. See the following table for detail. When they are set to **ON, ON, ON**, the microstep can be set via Leadshine PC software.

Micro step	Pulses/Rev.	SW6	SW7	SW8
1	200 (Default)	ON	ON	ON
2	400	OFF	ON	ON
2.5	500	ON	OFF	ON
5	1000	OFF	OFF	ON
10	2000	ON	ON	OFF
20	4000	OFF	ON	OFF
250	5000	ON	OFF	OFF
500	10000	OFF	OFF	OFF

5.4 Smoothing Filter Table (SW9-SW10)

3DM580S has an advanced feature called control command smoothing to make the input pulse from pulse generator (controller, PLC, etc.) S-curve acceleration, to improve motion smoothness and high-speed start frequency in many circumstances. This is achieved through adding filtering time which is configured SW9-SW10. See the following table for how to configure.

Smoothing Time	SW9	SW10
0ms (Disable)	ON	ON
6ms	OFF	ON
12ms	ON	OFF
25ms (Default)	OFF	OFF

Note: The Filter Time value must be set to the same for each 3DM580S in multi-axis applications

5.5 Motion Mode Configuration (SW11)

SW11=off: Low Speed Smooth Mode, suitable for applications requiring high smoothness at low speeds.

SW11=on: Large Torque Mode, suitable for applications requiring high output torque for high speeds.

5.6 Alarm Output Configuration (SW12)

DIP switch SW12 is used to configure the impedance state of alarm output (fault output).

When SW12 is set to OFF (factory setting) the resistance between ALM and COM- is set to low impedance in normal operation, and will change to high impedance when the drive goes into fault.

When SW12 is set to ON position, that resistance will be set to high impedance in normal condition and changed to low impedance under error protections.

Note: Alarm output resistance setting according to customer's actual requirements

5.7 Activated Pulse Edge Configuration (SW13)

DIP switch SW13 is used to configure activated pulse edge.

Setting it to OFF position (factory setting) means that a pulse is activated at voltage falling edge,.

Setting it to ON position means a pulse is activated at rising edge. Make sure this setting will match the pulse generator (controller, PLC, etc.).

5.8 Pulse Mode Configuration (SW14)

DIP switch SW14 is used to configure the pulse mode.

Setting to OFF (Factory setting) is single pulse (step & direction, or pulse &direction) control.

Setting to ON to change the control model to double pulse (CW/CCW) control type.

5.9 Shaft Lock in Non-enabled State (SW15)

SW15=off: when the Drive is non-enabled, it does not respond to pulses, there is no current output, and the motor is not locked (factory setting).

SW15=on: When the Drive is not enabled, it does not respond to pulse, there is current output, and the motor is locked.

5.10 Self-Test Configuration (SW16)

SW16=off: self-test disabled (factory default).

SW16=on: self-test enabled, the motor turns forward one revolution and then reverses one revolution at 0.2R/S

6. Power Supply Selection

The 3DM580S can power small and medium size 3-phase stepper motors (frame size from NEMA17 to 34) from Leadshine or other motor manufacturers. To get good system performance, it is important to select proper supply voltage and output current. Generally speaking, supply voltage determines the high speed performance of the motor, while output current determines the output torque of the driven motor (particularly at lower speed). Higher supply voltage will allow higher motor speed to be achieved, at the price of more noise and heating. If the motion speed requirement is low, it's better to use lower supply voltage to decrease noise, heating and improve reliability.

6.1 Regulated or Unregulated Power Supply

Both regulated and unregulated power supplies can be used to supply the drive. However, unregulated power supplies are preferred due to their ability to withstand current surge and fast response for current change. If you prefer to a regulated power supply, it is suggested to choose such a power supply specially designed for stepper/servo controls such as Leadshine LSP series . Or, in the case when only normal switching power supplies are available, it is important to use “OVERSIZE” high current output rating power supplies (for example, using a 4A power supply for 3A stepper motor) to avoid problems such as current clamp. On the other hand, if unregulated supply is used, one may use a power supply of lower current rating than that of motor (typically 50%-70% of motor current). The reason is that the drive draws current from the power supply capacitor of the unregulated supply only during the ON duration of the PWM cycle, but not during the OFF duration. Therefore, the average current withdrawn from power supply is considerably less than motor current. For example, two 3A motors can be well supplied by one power supply of 4A rating.

6.2 Power Supply Sharing

Multiple 3DM580S drives can share one power supply to save space and reduce cost, if that power supply has enough power capacity. To avoid cross interference, connect each stepper drive directly to the shared power supply separately. To avoid cross interference, DO NOT daisy-chain connect the power supply input pins of the Drivers. Instead connect them to power supply separately.

6.3 Selecting Supply Voltage

The 3DM580S is designed to operate under 74VDC voltage input. When selecting a power supply, besides voltage from the power supply power line voltage fluctuation and back EMF voltage generated during motor deceleration needs also to be taken into account. Ideally it is suggested to use a power supply with the output of 20-48VDC, leaving room for power line voltage fluctuation and back-EMF.

Higher supply voltage can increase motor torque at higher speeds, thus helpful for avoiding losing steps. However, higher voltage may cause bigger motor vibration at lower speed, and it may also cause over-voltage protection or even drive damage. Therefore, it is suggested to choose only sufficiently high supply voltage for intended applications.

Model	Output Voltage (VDC)	Continuous Current(A)	Peak Current(A)	Input Voltage	Power (W)	Dimensions (mm)	Weight (Kg)
LSP-260-24	24	10.8	19.4	220VAC ± 10% or 110 VAC ± 10%	260	199*110*50	0.8
LSP-360-24	24	15	27		360	199*110*50	0.8
LSP-360-36	36	10	18		360	215*115*30	0.7
LSP-360-48	48	7.5	13.5		360	215*115*30	0.7
LSP-400-60	60	6.7	12		400	215*115*30	0.7

7. Motor Selection

The 3DM580S can be used to drive 3- or 6-wire three-phase hybrid stepper motors with a step angle of 1.2 degrees. The choice of motor is mainly determined by the motor torque and current rating. The torque size is mainly determined by the size of the motor. The larger the size of the motor, the higher the torque of the motor; while the current size is mainly related to the inductance, the motor with small inductance has good performance in high speed performance, but the current is higher.

Model	Length (mm)	Holding Torque(N.m)	Rate Current (A)	Resistance/Phase(Ω)	Inductance/Phase(mH)	Inertia (Kg.cm ²)
573S09	50	0.9	3.5	0.77	1.8	1.00
573S15	76	1.3	5.8	0.86	2.0	1.40
863S22	71	2.3	5	0.9	2.8	2.50
863S42	103	4.3	5	1.35	4.5	2.70

8. Troubleshooting

In the event that your drive doesn't operate properly, the first step is to identify whether the problem is electrical or mechanical in nature. The next step is to isolate the system component that is causing the problem. As part of this process you may have to disconnect the individual components that make up your system and verify that they operate independently. It is important to document each step in the troubleshooting process. You may need this documentation to refer back to at a later date, and these details will greatly assist our Technical Support staff in determining the problem should you need assistance.

Many of the problems that affect motion control systems can be traced to electrical noise, controller software errors, or mistake in wiring.

Problem Symptoms and Possible Causes

Trouble	Solution Measures
Motor is not rotating	No power, to start power supply
	Pulse/revolution setting is wrong
	DIP switch current setting is wrong
	Fault condition exists or the drive is disabled
Motor rotates in the wrong direction	Motor phases may be connected in reverse
	Pulse mode may be wrong
Red light blinking	Red light blinks 1 time or always on, try not to connect the motor and restart the power supply
	Red light blinks 2 times, check the power voltage and restart the power supply
Erratic motor motion	Current setting is too small, losing steps
	Wrong motor connection or has broken circuit in motor coil.
	The current of the control signals is not in the range of 7-15mA Control signals don't meet the requirements of chapter 4.3 , check the waveform of the control signals

Motor stalls or loss steps	Output current of the drive is too small or motor torque is not enough
	Acceleration is set too high
	Power supply voltage too low
	Modify the activated edge value in the PC software or the control signal is interfered with.
Excessive motor and drive heating	Inadequate heat sinking / cooling
	Automatic current reduction function not being utilized
	Reduce output current

9. Warranty

Twelve Month Warranty

Leadshine Technology Co., Ltd. warrants its products against defects in materials and workmanship for a period of 12 months from shipment out of factory. During the warranty period, Leadshine will either, at its option, repair or replace products which proved to be defective.

Exclusions

The above warranty does not extend to any product damaged by reasons of improper or inadequate handling by customer, improper or inadequate customer wiring, unauthorized modification or misuse, or operation beyond the electrical specifications of the product and/or operation beyond environmental specifications for the product.

Obtaining Warranty Service

To obtain warranty service, please contact your seller to obtain a returned material authorization number (RMA) before returning product for service.

Shipping Failed Products

If your product fail during the warranty period, please contact your seller for how and where to ship the failed product for warranty or repair services first, you can also e-mail customer service at tech@leadshine.com to obtain a returned material authorization number (RMA) before returning product for service. Please include a written description of the problem along with contact name and address.