

DM542S

Digital Stepper Drive

Manual

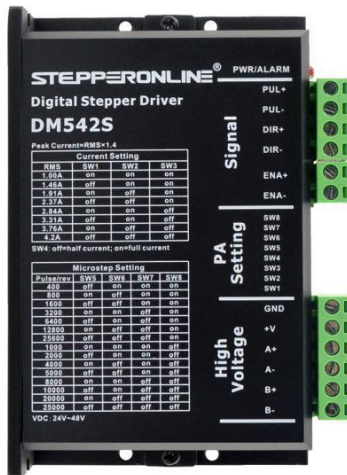

#7 Zhongke Road, Jiangning, Nanjing, China

Tel: 0086-2587156578

Web site: www.omc-stepperonline.com

E-Mail: sales@stepperonline.com

Contents

1. Overview	- 1 -
2. Features	- 1 -
3. Ports Introduction	- 2 -
3.1 Control Signal Input Ports	- 2 -
3.2 Power Interface Ports.....	- 3 -
4. Technological Index	- 4 -
5. Connections to Control Signal	- 5 -
5.1 Connections to Common Anode.....	- 5 -
5.2 Connections to Common Cathode	- 6 -
5.3 Connections to Differential Signal	- 7 -
5.4 Sequence Chart of Control Signals.....	- 8 -
6. DIP Switch Setting	- 9 -
6.1 Current Setting.....	- 9 -
6.2 Standstill current Setting... ..	- 9 -
6.3 Microsteps Setting.....	- 9 -
7. Faults alarm and LED flicker frequency	- 11 -
8. Appearance and Installation Dimensions	- 12 -
9. Typical Connection	- 13 -
10. Processing Methods to Common Problems and Faults	- 14 -
10.1 The power light is off.....	- 14 -
10.2 The drive alarms when power on.....	- 14 -
10.3 The motor does not rotate after being given pulse signals..	- 14 -

1. Overview

The DM542S is a two phase digital stepper driver based on ARM. Its Microstep resolution and output current are programmable. And it has advanced control algorithm which brings a unique level of system smoothness, provides optimum torque and mid-range instability. The control algorithm of Multi-Stepping can allow stepper motor a smooth system performance. The control algorithm of torque compensation can improve the torque of motor at high speed. The control algorithm of motor self-test and parameter auto-setup technology offers optimum responses with different motors and easy-to-use. The control algorithm of smoothness can enhance the acceleration and deceleration of motor. Its unique features make the DM542S an ideal solution to applications.

2. Features

- ◆ Parameter auto-setup and motor self-test
- ◆ Multi-Stepping inside, Small noise, low heat, smooth movement
- ◆ Torque compensation at high speed
- ◆ Variable current control technology, High current efficiency
- ◆ Accelerate and decelerate control inside, Great improvement in smoothness of starting or stopping the motor
- ◆ Storage the position of motor
- ◆ Optically isolated input and compatible with 5V ~ 24V
- ◆ User-defined microsteps
- ◆ Over current and over voltage protection

- ◆ Automatic detection, flexible selection of pulse edge count mode;
- ◆ Green light means running while red light means protection or off line

3. Ports Introduction

3.1 Control Signal Input Ports

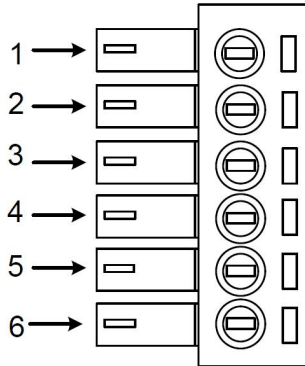

Port	Symbol	Name	Remark
1	ENA-	Pulse signal +	Compatible with 5V ~ 24V
2	ENA+	Pulse signal -	
3	DIR-	Direction signal+	Compatible with 5V ~ 24V
4	DIR+	Direction signal-	
5	PLS-	Enable signal +	Compatible with 5V ~ 24V
6	PLS+	Enable signal-	

3.2 Power Interface Ports

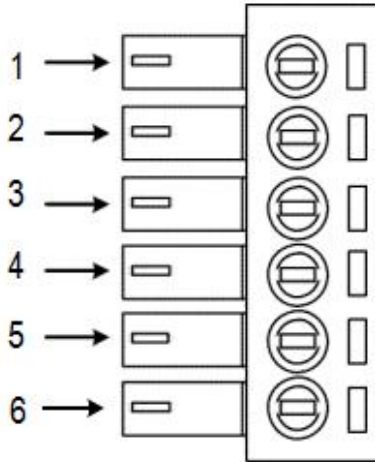

Port	Symbol	Name	Remark
1	B-	Phase B-	Motor Phase B
2	B+	Phase B+	
3	A-	Phase A-	Motor Phase A
4	A+	Phase A+	
5	V	Input Power +	DC24 ~ 48V
6	GND	Input Power -	

4. Technological Index

Input Voltage	DC24V-48V	
Max Pulse Frequency	200k	
Default communication rate	57.6kbps	
Protection	Overcurrent protection, peak $10A \pm 10\%$	
	Over voltage protection peak 60VDC	
Overall Dimensions(mm)	118×75.5×34	
Weight	Approximate 260g	
Environment	Environment	Avoid dust, oil fog and corrosive gases
	Operating Temperature	0 ~ 70°C
	Storage Temperature	-20°C~+80°C
	Humidity	40~90%RH
	Cooling method	Natural cooling or forced air cooling

5. Connections to Control Signal

5.1 Connections to Common Anode

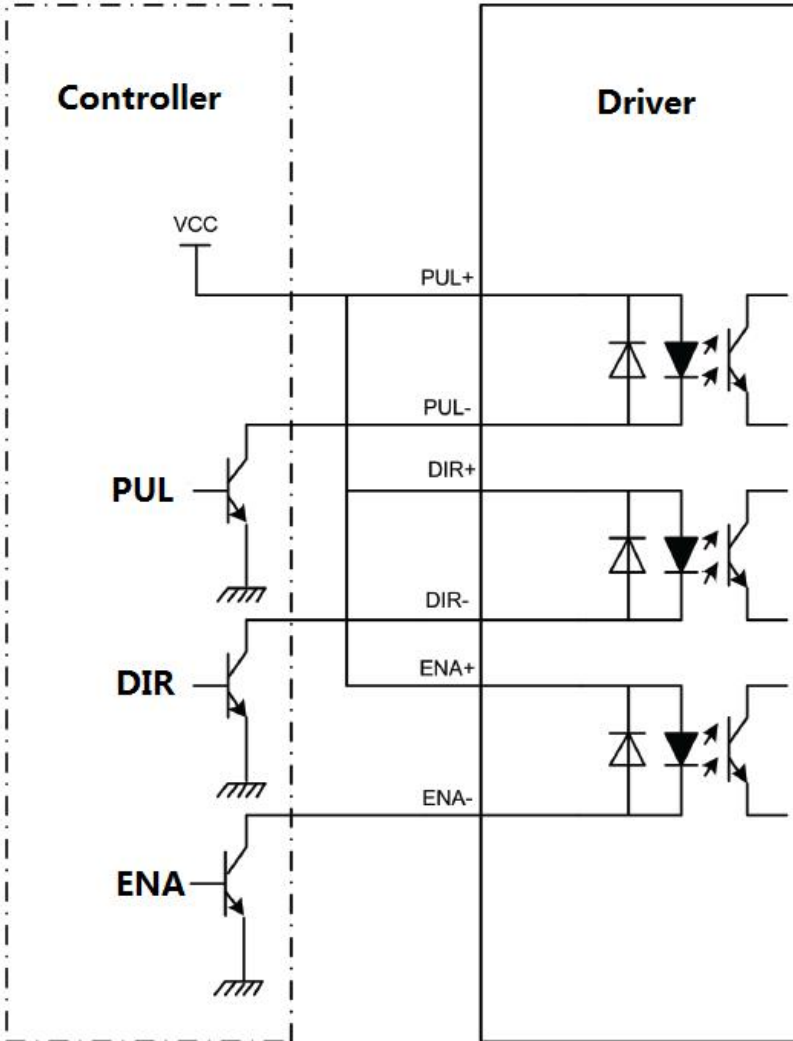

Remark:

VCC is compatible with 5V ~ 24V;

5.2 Connections to Common Cathode

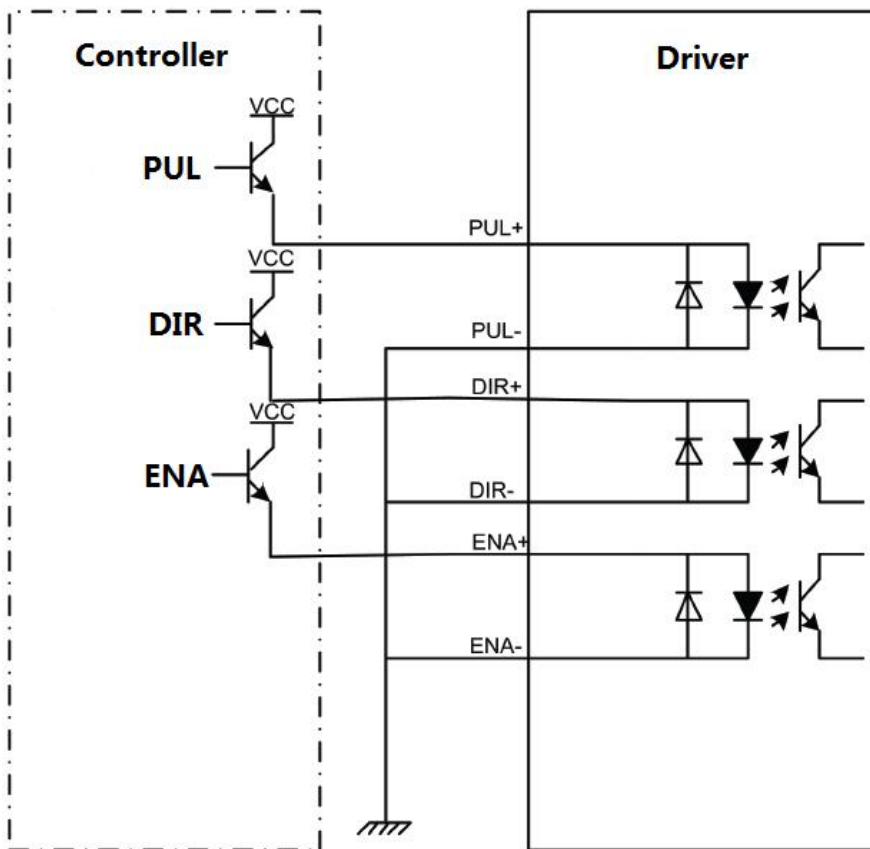

Remark:

VCC is compatible with 5V ~ 24V;

5.3 Connections to Differential Signal

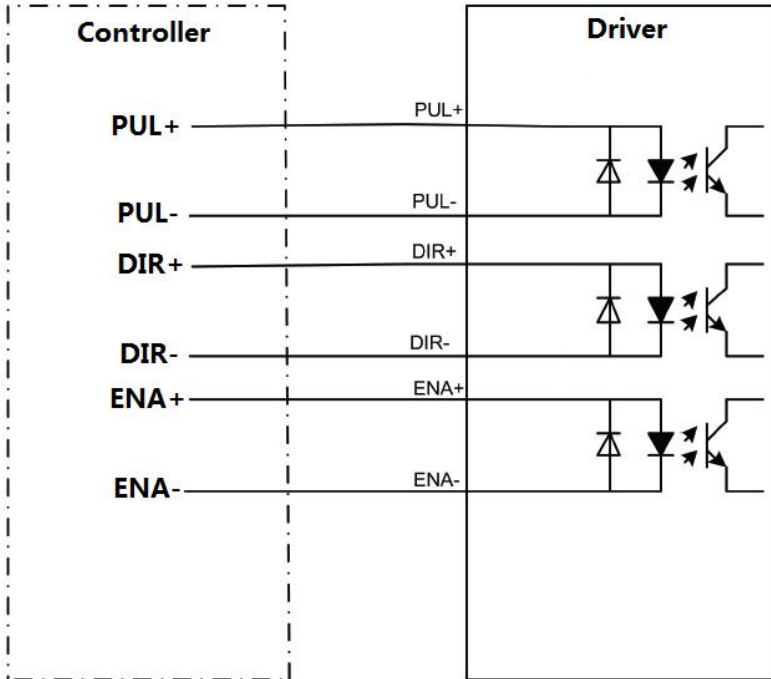
**Remark:**

VCC is compatible with 5V ~ 24V.

5.4 Sequence Chart of Control Signals

In order to avoid some fault operations and deviations, PUL, DIR and ENA should abide by some rules, shown as following diagram:

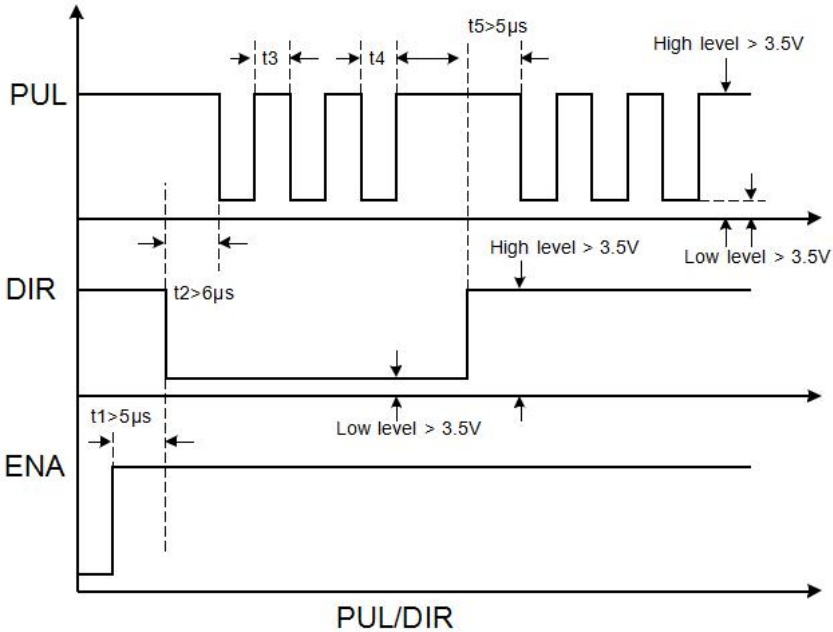

Remark:

- t_1 : ENA must be ahead of DIR by at least $5\ \mu\text{s}$. Usually, ENA+ and ENA- are NC (not connected).
- t_2 : DIR must be ahead of PUL active edge by $6\ \mu\text{s}$ to ensure correct direction;
- t_3 : Pulse width not less than $2.5\ \mu\text{s}$;
- t_4 : Low level width not less than $2.5\ \mu\text{s}$.

6. DIP Switch Setting

6.1 Current Setting

The current setting is in the following table.

Dial switch Current	SW1	SW2	SW3
RMS			
1.0A	on	on	on
1.46A	off	on	on
1.91A	on	off	on
2.37A	off	off	on
2.84A	on	on	off
3.31A	off	on	off
3.76A	on	off	off
4.2A	off	off	off

6.2 Standstill current Setting

SW4 is used for setting the standstill current , “off” means the standstill current is set to be half of the selected dynamic current or other current. While “on” means the standstill current is set to be the same as the selected dynamic current.

6.3 Microsteps Setting

The Microsteps setting is in the following table.

Dial switch Microsteps	SW5	SW6	SW7	SW8
400	off	on	on	on
800	on	off	on	on
1600	off	off	on	on
3200	on	on	off	on
6400	off	on	off	on
12800	on	off	off	on
25600	off	off	off	on
1000	on	on	on	off
2000	off	on	on	off
4000	on	off	on	off
5000	off	off	on	off
8000	on	on	off	off
10000	off	on	off	off
20000	on	off	off	off
25000	off	off	off	off

7. Faults alarm and LED flicker frequency

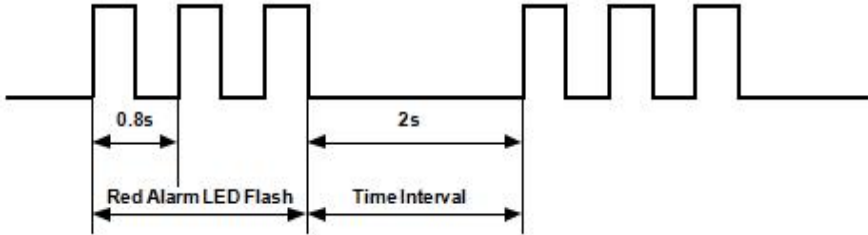

Flicker Frequen	Description to the Faults
1	Error occurs when the motor coil current exceeds the drive's current limit.
2	Voltage reference error in the drive
3	Parameters upload error in the drive
4	Error occurs when the input voltage exceeds the drive's voltage limit.

8. Appearance and Installatlon Dimensions

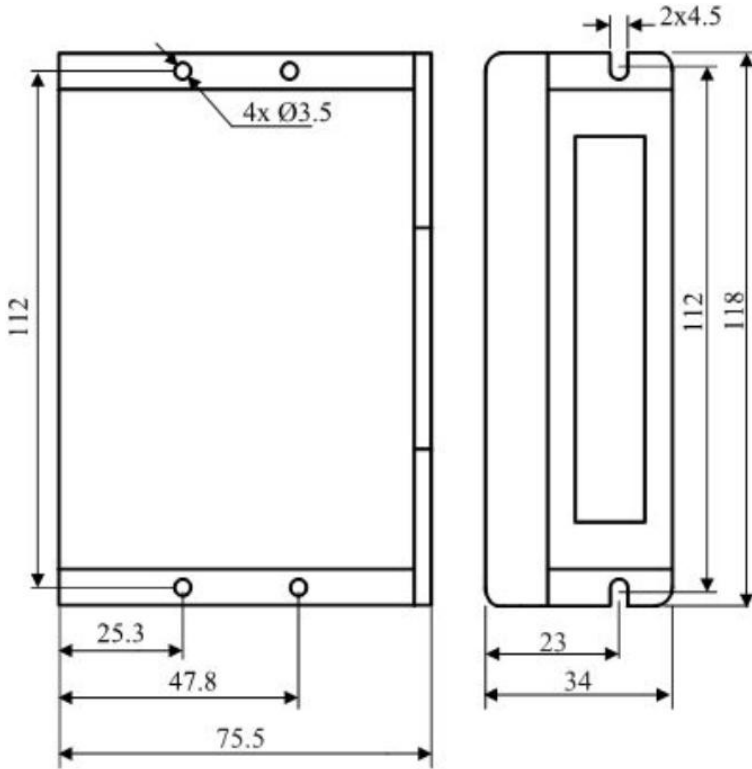

9. Typical Connection

Here is the typical connection of DM542S.

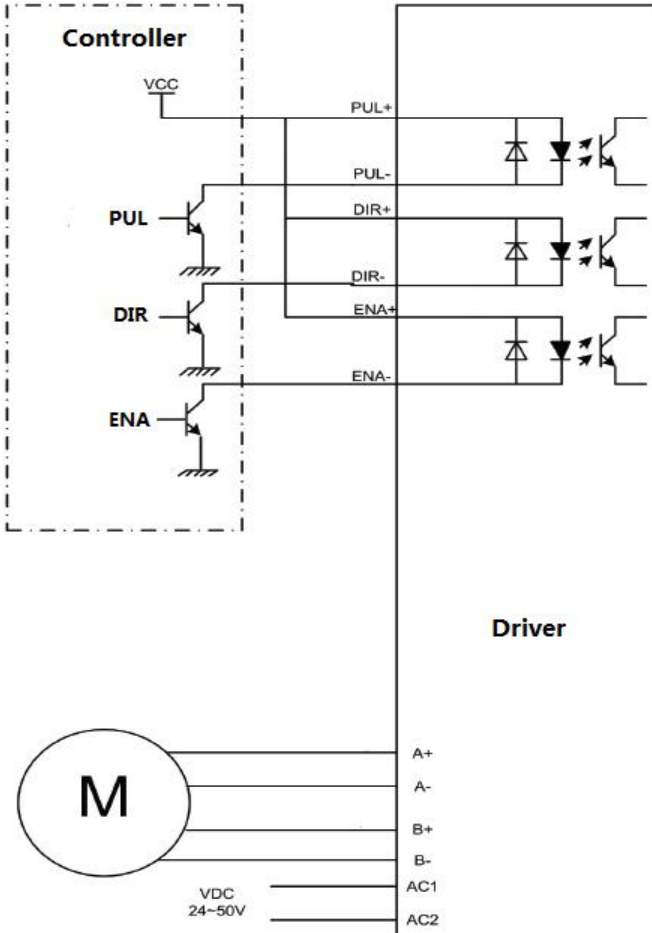

10. Frequently Asked Questions

10.1 The power light is off

- No power input, please check the power supply circuit.
- The voltage is too low.

10.2 The drive alarms when power on

- Please check the motor is connected with the drive.
- The stepper digital drive is over voltage or under voltage. Please lower or increase the input voltage.

10.3 The motor does not rotate after being given pulse signals

- Please check the input pulse signal wires are connected in reliable way.
- Please make sure the input pulse mode is corresponding with the real input mode.
- The Driver is disabled.