

CUSTOMER'S MODEL: NO MODEL  
 END COVER COLOR: GRAY

REV.	REVISION RECORD	BY	DATE
0	ORIGIN	LJ	10.14.2025

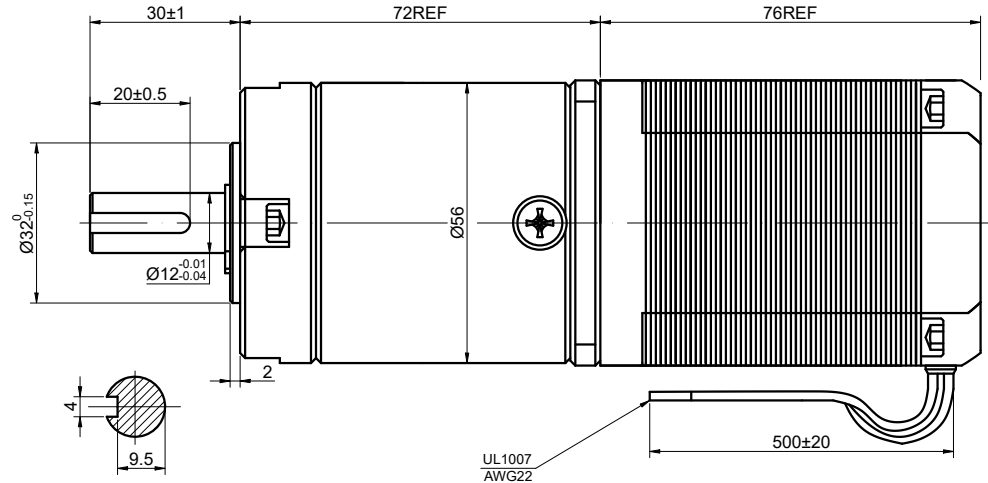
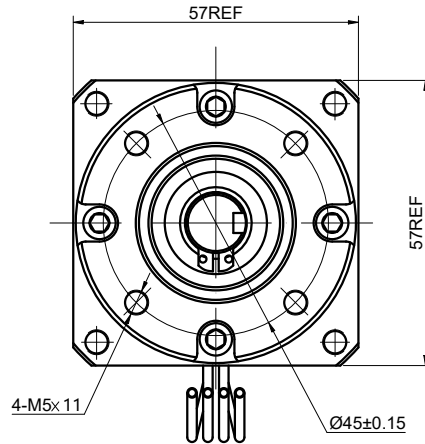

SPECIFICATION	CONNECTION	BIPOLAR
AMPS/PHASE		2.80
RESISTANCE/PHASE(Ohms)@25°C		1.13±10%
INDUCTANCE/PHASE(mH)@1KHz		5.40±20%
HOLDING TORQUE w/o GEARBOX(Nm)[lb-in]		1.90[16.82]
STEP ANGLE w/o GEARBOX(°)		1.80±5.00%
GEAR RATIO		46 <sup>82</sup> / <sub>125</sub>
MAX.PERMISSIBLE TORQUE(Nm)		30.00
MOMENT PERMISSIBLE TORQUE(Nm)		50.00
EFFICIENCY		70%
BACKLASH@NO-LOAD(°)		<=3°
WEIGHT(Kg)[lb]		-
AMBIENT TEMPERATURE		-10°C~50°C[14°F~122°F]
INSULATION CLASS		B 130°C[266°F]
TEMPERATURE RISE		MAX.80°C

COMMENT:

- 1.MAX. AXIAL LOAD:100N
- 2.MAX. RADIAL LOAD:200N
- 3.TMBF 6000h OR MORE @ 24V/300RPM
- 4.INSULATION RESISTANCE (NORMAL TEMPERATURE AND HUMIDITY): 100 Mohm
- 5.DIELECTRIC STRENGTH 500VAC FOR 1MIN.(BETWEEN THE MOTOR COILS AND THE MOTOR CASE )

MOTOR CONNECTION			
PIN NO	BIPOLAR	LEADS	WINDING
1	A+	BLK	
2	A-	GRN	
3	B+	RED	
4	B-	BLU	

FULL STEP 2 PHASE-Ex.,WHEN FACING MOUNTING END (X)					DIMENSIONS ARE IN MILLIMETERS.	
STEP	A+	B+	A-	B-	CCW	TOLERANCES AS BELOW:
1	+	+	-	-		DECIMALS
2	-	+	+	-		X ±0.5
3	-	-	+	+		X.X ±0.25
4	+	-	-	+		X.XX ±0.13
						ANGLES
						±2°

**STEPPERONLINE®**

STEPPER MOTOR

23HS30-2804S-PG47

THIS DOCUMENT SHALL NOT BE REPRODUCED NOR SHALL THE INFORMATION CONTAINED HEREIN BE USED BY OR DISCLOSED TO OTHERS UNLESS EXPRESSLY AUTHORIZED IN BY WRITING STEPPERONLINE.

SIGNATURE		DATE
DRN	LJ	10.14.2025
APVD	LDJ	10.14.2025