

REV.	REVISION RECORD	BY	DATE
0	ORIGIN	ZPJ	8.26.2024

CUSTOMER'S MODEL: NO MODEL
 END COVER COLOR: BLACK

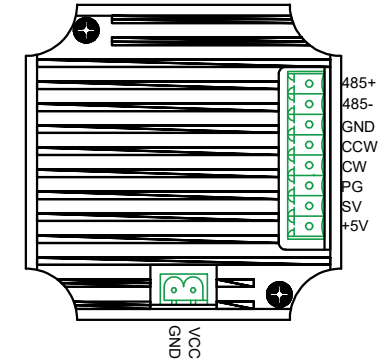
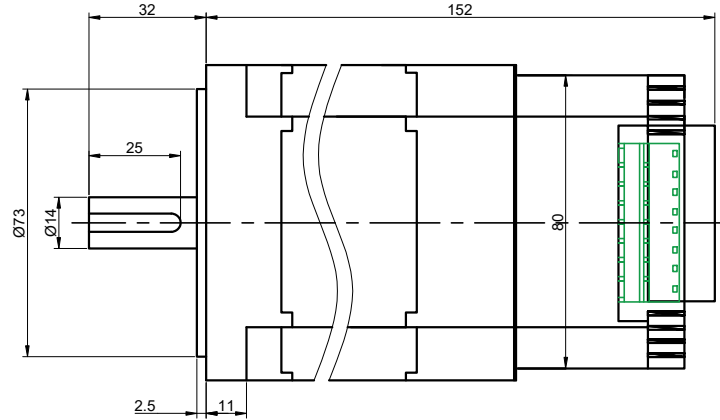
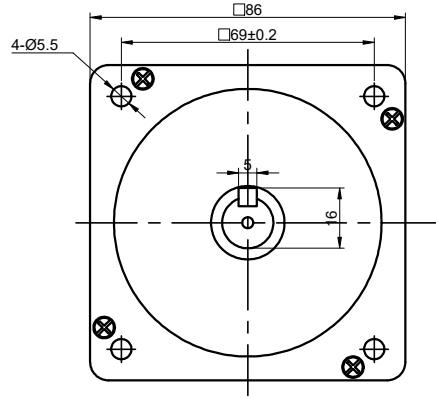

SPECIFICATION	VALUE
NO. of PHASES	3
NO. of POLES	8
RESISTANCE/PHASE(Ohms)@25°C	0.21±10%
INDUCTANCE/PHASE(mH)@1KHz	0.51±20%
RATED VOLTAGE(VDC)	24
RATED TORQUE(N.m)	1.27
RATED POWER(W)	200
RATED SPEED(RPM)	1500±10%
RATED CURRENT(A)	8.33±10%
Ke(V/krpm)	14.2
SENSOR	HALL
AMBIENT TEMPERATURE	-10°C~50°C[14°F~122°F]
INSULATION CLASS	B 130°C[266°F]
TEMPERATURE RISE	MAX.80°C

COMMENT:
 1.DYNAMIC AXIAL LOAD: --N MAX
 2.DYNAMIC RADIAL LOAD @ SHAFT LENGTH 20mm: --N MAX
 3.INSULATION RESISTANCE
 (NORMAL TEMPERATURE AND HUMIDITY): 100 Mohm
 4.DIELECTRIC STRENGTH: AC600V CUT OFF CURRENT 5mA FOR 1S

DIMENSIONS ARE IN MILLIMETERS.
 TOLERANCES AS BELOW:
 DECIMALS ANGLES
 X ±0.5 ±2°
 X.X ±0.25
 X.XX ±0.13



STEPPERONLINE®

INTEGRATED BRUSHLESS MOTOR

86IBL200-2415

THIS DOCUMENT SHALL NOT BE REPRODUCED NOR SHALL THE INFORMATION CONTAINED HEREIN BE USED BY OR DISCLOSED TO OTHERS UNLESS EXPRESSLY AUTHORIZED IN BY WRITING STEPPERONLINE.

SIGNATURE		DATE
DRN	ZPJ	8.26.2024
APVD	MYX	8.26.2024

REV.	0	SCALE	1:3	DWG NO.	A2676
------	---	-------	-----	---------	-------