

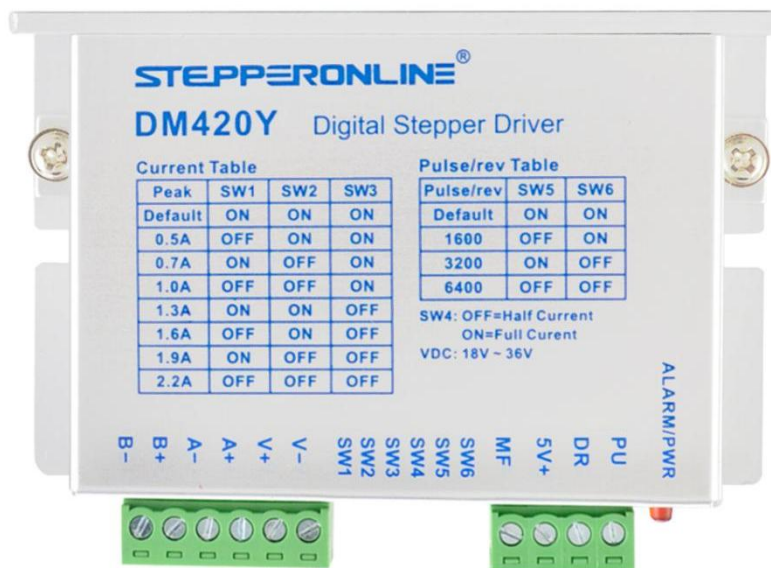

User Manual

DM420Y

Open Loop Stepper Driver



Pulse type open loop stepper driver instruction manual

Version: V1.0

©2025 All Rights Reserved

Address: 15-4, #799 Hushan Road, Jiangning, Nanjing, China

Tel: 0086-2587156578

Web: www.omc-stepperonline.com

Sales: sales@stepperonline.com

Support: technical@stepperonline.com

Catalogue

Revision history	1
Introduction	2
Chapter 1 Overview	3
1.1 Product introduction	3
1.2 Peculiarity	3
1.3 Application field	3
Chapter 2 Performance Indicators	4
2.1 Electrical characteristic	4
2.2 Using environment	4
Chapter 3 Installation	5
3.1 Mounting dimension	5
3.2 Installation Methods	5
Chapter 4 Driver Ports and Wiring	6
4.1 Wiring diagram	6
4.2 Port Definition	7
4.2.1 Status indicator light	7
4.2.2 Control signal input port	7
4.2.3 Power input and motor port	7
4.2.4 Dip switch	8
4.3 Input/output port operation	8
4.4 Signal input timing diagram	8
Chapter 5 Drive operation parameter Settings	9
5.1 Driver current setting	9
5.2 Drive subdivision Settings	9
5.3 Lock current	9
Chapter 6 Driver Status Indicators	10
Chapter 7 General Troubleshooting methods	11

Revision history

Version	Description	Date	Remark
V1.0	First edition release	2024.11.30	

Introduction

Thank you for using this stepper drive.

Before using this product, be sure to read this manual carefully to understand the necessary safety information, precautions, and operation methods.

The wrong operation can lead to extremely serious consequences.

Statement

The design and manufacture of this product does not have the ability to protect personal safety from the threat of mechanical systems. Users are requested to consider safety protection measures during the design and manufacture of mechanical systems to prevent accidents caused by improper operation or abnormal products.

Due to product improvements, the contents of the manual are subject to change without notice.

Our company will not be responsible for any modification of the product by the user.

When reading, please note the following marks in the manual:



Remind you to pay attention to the main points in the text.



Indicates that improper operations may result in personal injury or equipment damage.

Chapter 1 Overview

1.1 Product introduction

DM420Y is a high-performance digital stepper driver based on a new generation of 32-bit DSP technology, driving voltage DC18-36V. Adaptive peak current below 2.2A, external diameter 20mm, 28mm, 35mm, 42mm of various types of two-phase hybrid stepper motor.

The driver adopts the control principle similar to servo, unique circuit design and superior software algorithm processing, which makes the motor have superior performance in the performance of running smoothness, noise and vibration. Smooth and precise current control technology greatly reduces motor heating; External 8-speed equal Angle constant torque subdivision, up to 128 subdivision; Optocoupler isolated common positive signal input, strong anti-interference ability; With over-voltage, under-voltage and other error protection function; In medical equipment, dispenser, laser engraving and other medium and low speed applications, its stability, low vibration, low noise advantages are obvious, can greatly improve the performance of equipment.

1.2 Peculiarity

- A new generation of 32-bit DSP control technology, high cost performance, good stability, superior noise, vibration performance;
- Optical coupling isolated common positive signal input, strong anti-interference ability;
- New motor parameter identification function, can identify the motor and given control parameters, play its best performance;
- Smooth and accurate current control, low motor heat;
- The highest impulse response frequency up to 200KHz;
- When the stepping pulse stops for more than 200ms, the motor current will be halved.
- Input voltage range is DC18-36V;
- The peak driving current is adjustable below 2.2A;
- Equip over voltage, under voltage, and other error protection function;
- Low frequency subdivision has excellent stability;

1.3 Application field

Mainly used in medical equipment, dispenser, engraving machine, laser equipment, labeling machine, electronic equipment, advertising equipment and other automation equipment. The application effect is especially good in the equipment that users expect low heat, small noise, low vibration, high stability and high precision.

Chapter 2 Performance Indicators

2.1 Electrical characteristic

argument	DM420Y			
	Minimum value	Typical value	Maximum value	Unit
Continuous output current	0	-	2.2	A
Input supply voltage	18	24	36	Vdc
Logic input current	7	10	20	mA
Pulse frequency	0	-	200	kHz
Insulation resistance	50	-	-	MΩ

2.2 Using environment

Cooling mode	Natural cooling	
Use environment	Use occasion	Try to stay away from other heating equipment, avoid dust, oil mist, corrosive gas, strong vibration places, flammable gas and conductive dust are prohibited
	Temperature	0°C~50°C
	Humidity	40—90%RH (non-condensation)
	Vibration	10~55Hz/0.15mm
Storage temperature	-20°C~+70°C	

Chapter 3 Installation

3.1 Mounting dimension

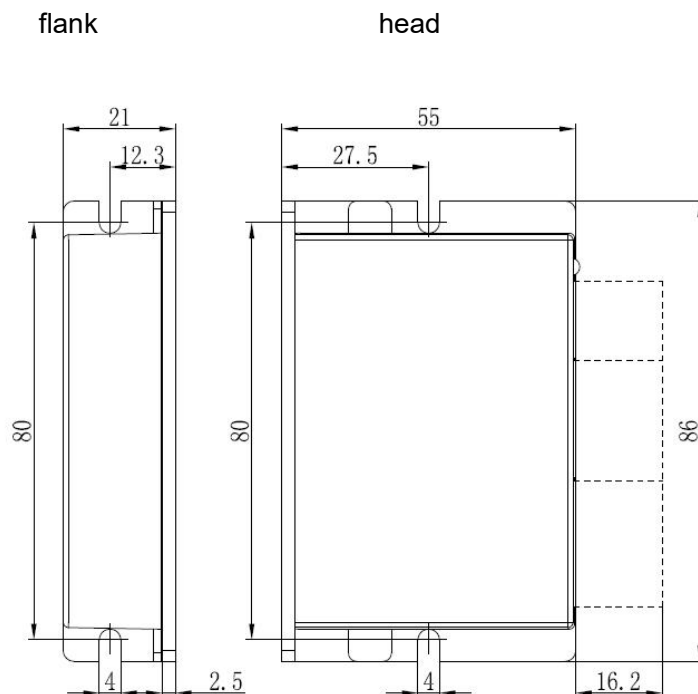

Installation size drawing (unit: mm)

3.2 Installation Methods

When installing the driver, please use the upright side installation to form strong air convection on the driver surface; If necessary, install a fan close to the driver to force the heat to dissipate to ensure that the driver works within the reliable operating temperature range (the reliable operating temperature of the driver is usually within 50°C, and the operating temperature of the motor is within 80°C).

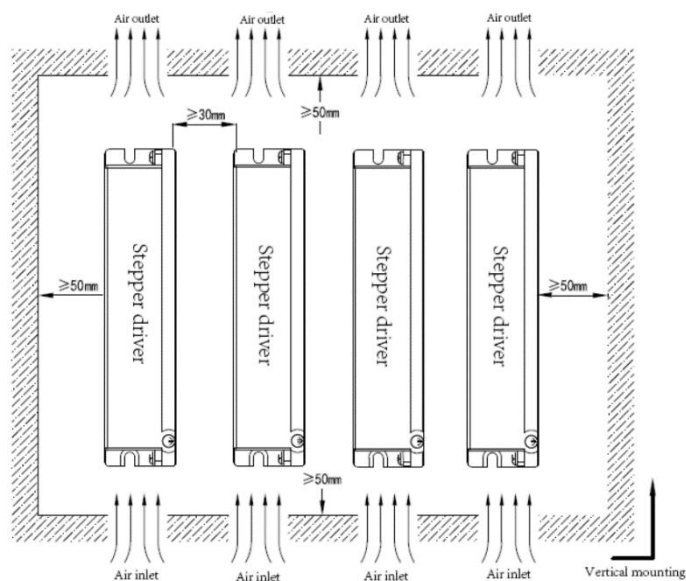

Chapter 4 Driver Ports and Wiring

4.1 Wiring diagram

Use the DM420Y drive according to the interface diagram:

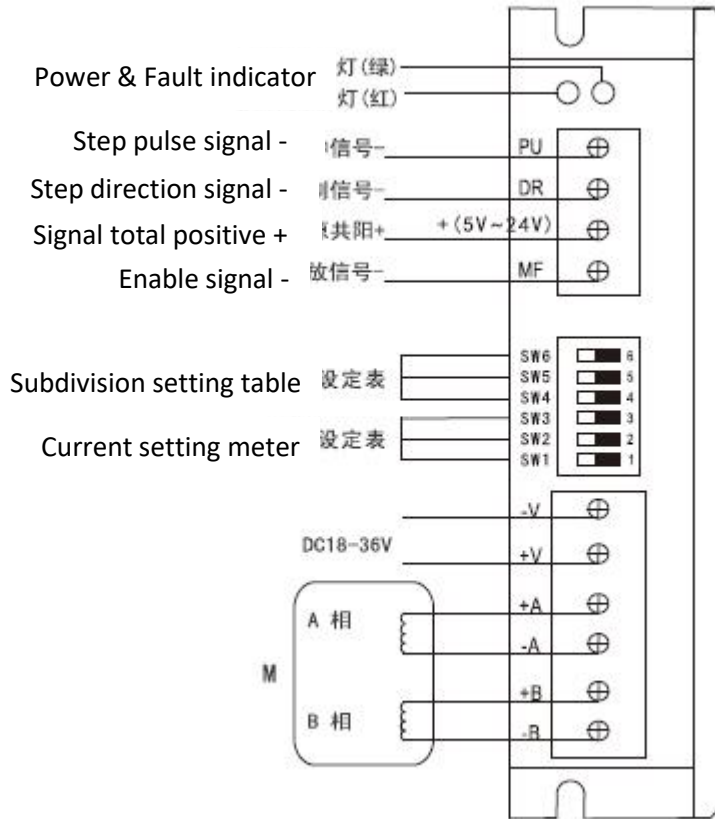

Attention!

- The personnel involved in wiring must have professional ability.
- No live wiring.
- The wiring can only be carried out after the installation is firm.
- Do not connect the power supply wrong, the input voltage should not exceed 36V.

4.2 Port Definition

4.2.1 Status indicator light

Color	Name	Features
Green	Power indicator light	When the power is on, the green indicator lights up.
Red	Fault indicator light	Drive overcurrent: Flash once; Drive overvoltage: Flash twice; Drive undervoltage:Flash three times;

4.2.2 Control signal input port

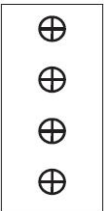
Port	Lead	Symbol	Feature	Annotation
	1	PU	Pulse signal photoelectric isolation negative end	The falling edge is effective, and every time the pulse changes from high to low, the motor takes a step.
	2	DR	Directional signal photoelectric isolation negative end	Used to change motor steering.
	3	5V+	The signal power supply has a total positive input	Signal input positive end, +5~24V input, higher than 24V need to connect the current limiting resistance.
	4	MF	Release signal photoelectric isolation negative end	When effective, turn off the motor coil current, and the motor is in a free state.

4.2.3 Power input and motor port

Port	Lead	Symbol	Name	Function
	1	V-	Power interface	DC18-36V
	2	V+		
	3	A+	Motor interface	Two phase stepper motor connector
	4	A-		
	5	B+		
	6	B-		

4.2.4 Dip switch

Port	Lead	Symbol	Function
	1	SW1	Current value setting
	2	SW2	
	3	SW3	
	4	SW4	Subdivision setting
	5	SW5	
	6	SW6	

4.3 Input/output port operation

The DM420Y driver has three digital inputs, photoelectric isolation, and the signal supports 5V-24V input. When the input signal is higher than 24V, the series current limiting resistance is required at the signal input end. The specific wiring diagram is as follows:
input:

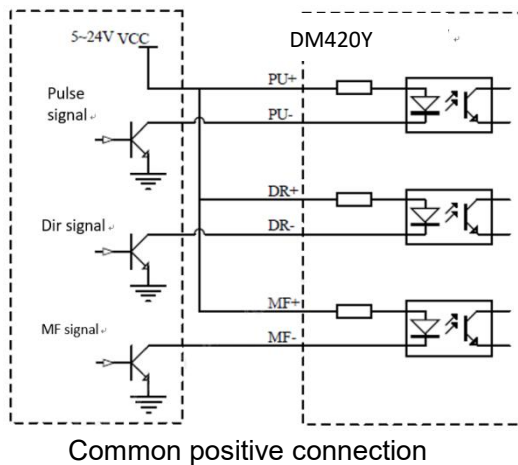

4.4 Signal input timing diagram

DM420Y driver In order to avoid abnormal operation of the driver control motor, please refer to the following diagram for the timing diagram of the input signal:

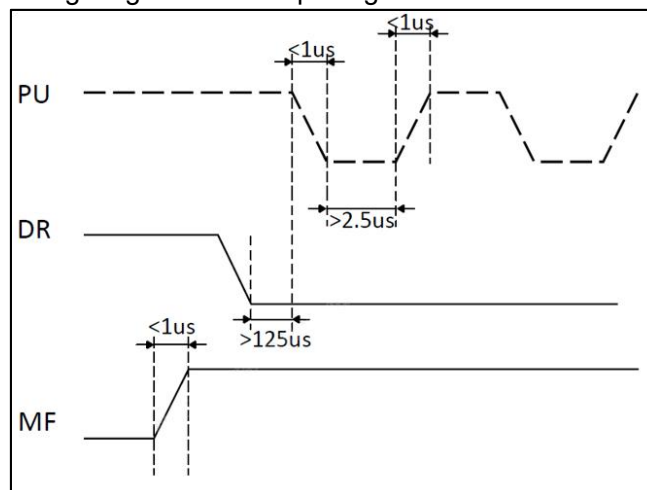

Chapter 5 Drive operation parameter Settings

The DM420Y stepper motor driver uses a 6-bit dip switch to set the driver current and subdivision. The specific Settings are as follows:

5.1 Driver current setting

The DM420Y driver sets the peak output current or RMS value through SW1, SW2, SW3 dip switches.

Normally, the current is set to the rated current of the motor. If your system has high heating requirements, you can appropriately reduce the current to reduce the heat of the motor, but the output torque of the motor will be reduced at the same time. If you do not require continuous operation of the motor, you can appropriately increase the running current to obtain greater torque.

DM420Y Ammeter of current: (unit:A)

Current RMS	Current PEAK	SW1	SW2	SW3
Default	Default	ON	ON	ON
0.4	0.5	OFF	ON	ON
0.5	0.7	ON	OFF	ON
0.7	1.0	OFF	OFF	ON
0.9	1.3	ON	ON	OFF
1.1	1.6	OFF	ON	OFF
1.4	1.9	ON	OFF	OFF
1.6	2.2	OFF	OFF	OFF

Remark: Current RMS is the effective value, current Peak is the peak value of current

5.2 Drive subdivision Settings

DM420Y driver through SW4, SW5, SW6 dial switches to set the corresponding subdivision, as shown in the table below:

Subdivision	PU/Rev	SW4	SW5	SW6
1	200	ON	ON	ON
2	400	OFF	ON	ON
4	800	ON	OFF	ON
8	1600	OFF	OFF	ON
16	3200	ON	ON	OFF
32	6400	OFF	ON	OFF
64	12800	ON	OFF	OFF
128	25600	OFF	OFF	OFF

5.3 Lock current

The DM420Y drive defaults to a half-current lock.

Chapter 6 Driver Status Indicators

The DM420Y driver has an alarm prompt. After the driver alarms, the alarm indicator state indicates the alarm information of the driver. The specific alarm information is shown in the following table.

Fault information	ALM Pilot lamp	Resetting
Overcurrent or interphase short circuit	Flash once	Power-off reset
Overvoltage of supply	Flash twice	Automatic restoration of standard voltage
The power supply voltage is too low.	Flash three times	Automatic restoration of standard voltage

Chapter 7 General Troubleshooting methods

Phenomenon	Possible situation	Solution measure
Motor failure	The power light is off	Check the power supply circuit. The power supply is normal
	The motor locks the shaft but does not turn	The IO signal is weak and the signal current is increased
	Too little speed	Selection speed
	Whether the release signal MF is connected	Disconnect the MF signal
	Instruction input error	Check whether the upper computer has a switch output
Motor direction error	Motor reversal	Replace motor wiring sequence or adjust instruction direction
	The motor line has a break	Check whether the cable is in poor contact
	The motor has only one direction	Input port damage
The alarm indicator light is on	The motor wire is connected incorrectly	Check the wiring
	The voltage is too high or low	Check power supply
	The motor or drive is damaged	Replace the motor or drive
Wrong position or speed	Signal interference	Eliminate interference, reliable grounding
	Instruction input error	Check the upper computer instructions to ensure correct output
	Speed setting error	Check the DIP switch status and connect it correctly
	Motor tripping	Check whether the command speed is too large and the motor selection is small
The driver terminal is burned out	Short-circuit between terminals	Check the power polarity or external short circuit
	The internal resistance between terminals is too large	Check whether excess solder is added to the wire and wire connection to form tin pellets
Motor stalling	The acceleration and deceleration time is too short	Reduce the command acceleration or increase the driver filter parameter
	Motor torque too small	Select high torque motor
	Heavy load	Check the load weight and quality, adjust the mechanical structure
	Too little current	Check dip switches to increase the output current of the driver