

CUSTOMER'S MODEL: NO MODEL

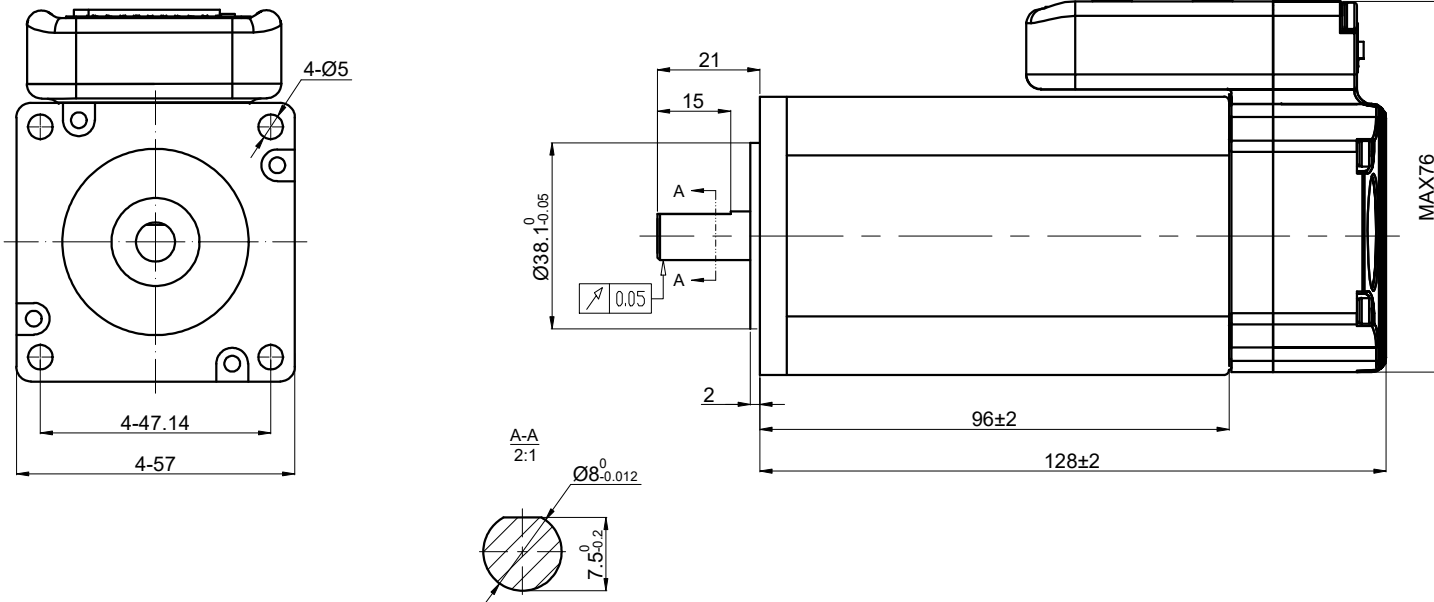

SPECIFICATION	VALUE
POWER (W)	130
RATED TORQUE (Nm)	0.45
PEAK TORQUE (Nm)	1.1
RATED SPEED (RPM)	$3000 \pm 10\%$
PEAK SPEED (RPM)	$4000 \pm 10\%$
RATED VOLTAGE (VDC)	36
INERTIA (kg.cm ²)	394
INPUT VOLTAGE (V)	20~50
RATED CURRENT(A)	5.6
CONTINUOUS CURRENT(Arms)	0.55
LOGIC SIGNAL CURRENT (mA)	10
ISOLATION RESISTANCE (MΩ)	100
PROTECTION LEVEL	IP54 FOR MOTOR/IP20 FOR DRIVE
WEIGHT (Kg) [lb]	1.25[2.76]

THIS DOCUMENT SHALL NOT BE REPRODUCED NOR SHALL THE INFORMATION CONTAINED HEREIN BE USED BY OR DISCLOSED TO OTHERS UNLESS EXPRESSLY AUTHORIZED IN BY WRITING STEPPERONLINE.		DIMENSIONS ARE IN MILLIMETERS. TOLERANCES AS BELOW: DECIMALS ANGLES X ±0.5 ±2° X.X ±0.25 X.XX ±0.13	
		SIGNATURE	DATE
DRN	HW	6.27.2024	THIRD ANGLE PROJECTION
APVD	LDJ	6.28.2024	

SERVO MOTOR			
iSV57T-130S			
REV.	0	SCALE	1:1.5
DWG NO.	A1868	DATE	6.27.2024