

CUSTOMER'S MODEL: NO MODEL  
 END COVER COLOR: GRAY

REV.	REVISION RECORD	BY	DATE
0	ORIGIN	MYX	8.1.2025

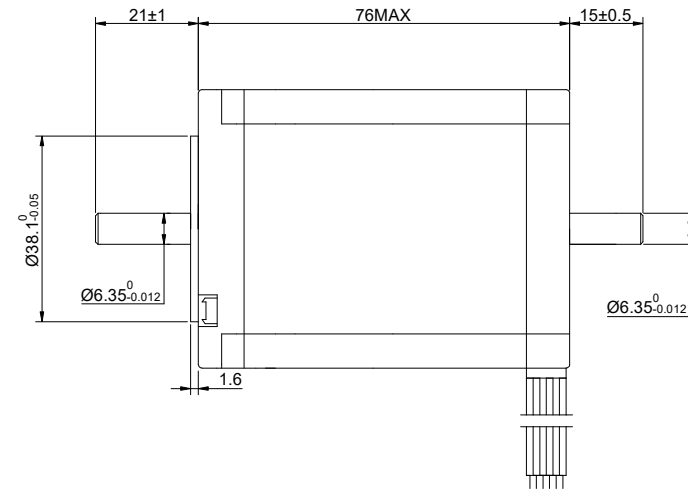

STEPPER MOTOR  
 23HS30-3006D  
 S/N: XXXXXXXXXXXXX

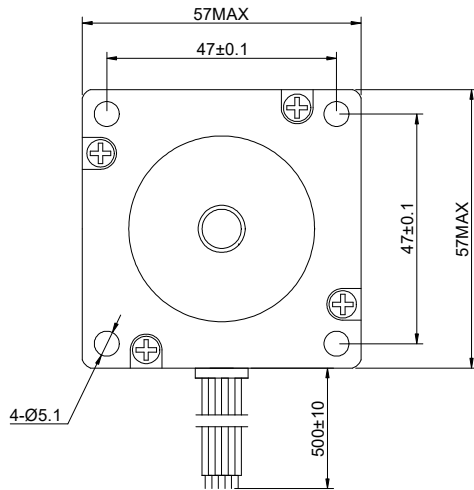

SPECIFICATION	CONNECTION	
	UNIPOLAR	BIPOLAR
AMPS/PHASE	3.00	2.12
RESISTANCE/PHASE(Ohms)@25°C	1.00±10%	2.00±10%
INDUCTANCE/PHASE(mH)@1KHz	1.60±20%	6.40±20%
HOLDING TORQUE(Nm)[lb-in]	1.35[11.95]	1.90[16.82]
STEP ANGLE(°)	1.80	
STEP ACCURACY(NON-ACCUM)	±5.00%	
ROTOR INERTIA(g-cm <sup>2</sup> )	480.00	
WEIGHT(Kg)[lb]	1.00[2.20]	
AMBIENT TEMPERATURE	-10°C~50°C[14°F~122°F]	
INSULATION CLASS	B 130°C[266°F]	
TEMPERATURE RISE	MAX.80°C	

COMMENT:

- 1.DYNAMIC AXIAL LOAD: 15N MAX
- 2.DYNAMIC RADIAL LOAD @ SHAFT LENGTH 20mm: 75N MAX
- 3.TMBF 6000h OR MORE @ 24V/300RPM
- 4.INSULATION RESISTANCE (NORMAL TEMPERATURE AND HUMIDITY): 100 Mohm
- 5.DIELECTRIC STRENGTH 500VAC FOR 1MIN.(BETWEEN THE MOTOR COILS AND THE MOTOR CASE )

FULL STEP 2 PHASE-EX.,WHEN FACING MOUNTING END (X)

STEP	A+	B+	A-	B-	O(O)
1	-	-			+
2		-	-		+
3			-	-	+
4	-			-	+

↓ CW      ↑ CCW

DIMENSIONS ARE IN MILLIMETERS.  
 TOLERANCES AS BELOW:  
 DECIMALS      ANGLES  
 X      ±0.5      ±2°  
 X.X      ±0.25  
 X.XX      ±0.13

THIRD ANGLE PROJECTION

MOTOR CONNECTION			
PIN NO	BIPOLAR	LEADS	WINDING
1	A+	BLK	
2	A -	GRN	
3	B+	RED	
4	B -	BLU	
5	O+	YEL	
6	O-	WHT	

**STEPPERONLINE®**

STEPPER MOTOR

23HS30-3006D

THIS DOCUMENT SHALL NOT BE REPRODUCED NOR SHALL THE INFORMATION CONTAINED HEREIN BE USED BY OR DISCLOSED TO OTHERS UNLESS EXPRESSLY AUTHORIZED IN BY WRITING STEPPERONLINE.

SIGNATURE		DATE
DRN	MYX	8.1.2025
APVD	ZPJ	8.1.2025

REV.	0	SCALE	2:3	DWG NO.	A1264
------	---	-------	-----	---------	-------