

CUSTOMER'S MODEL: NO MODEL
 END COVER COLOR: GRAY

REV.	REVISION RECORD	BY	DATE
0	ORIGIN	MYX	8.1.2025

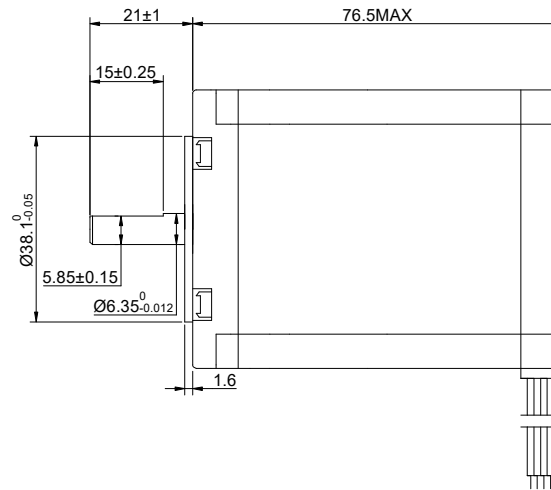
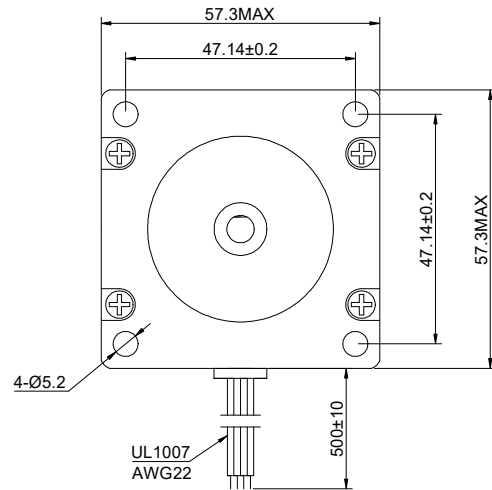

COMMENT:

1. MINOR ADJUSTMENTS MADE, NO PERFORMANCE IMPACT.

① PREVIOUS VALUE: 1.13Ω.

② PREVIOUS VALUE: 4.8mH.

③ PREVIOUS VALUE: 1.9Nm.

2. TMBF 6000h OR MORE @ 24V/300RPM

3. INSULATION RESISTANCE (NORMAL TEMPERATURE AND HUMIDITY): 100 Mohm

4. DIELECTRIC STRENGTH 500VAC FOR 1MIN.(BETWEEN THE MOTOR COILS AND THE MOTOR CASE)



MOTOR CONNECTION			
PIN NO	BIPOLAR	LEADS	WINDING
1	A+	BLK	
2	A-	GRN	
3	B+	RED	
4	B-	BLU	

SPECIFICATION	CONNECTION	BIPOLAR
AMPS/PHASE		2.80
RESISTANCE/PHASE(Ohms)@25°C		1.17±10% ^①
INDUCTANCE/PHASE(mH)@1KHz		4.36±20% ^②
HOLDING TORQUE(Nm)[lb-in]		2.00[17.7] ^③
STEP ANGLE(°)		1.80
STEP ACCURACY(NON-ACCUM)		±5.00%
ROTOR INERTIA(g-cm²)		300
WEIGHT(Kg)[lb]		-
AMBIENT TEMPERATURE		-10°C~50°C[14°F~122°F]
INSULATION CLASS		B 130°C[266°F]
TEMPERATURE RISE		MAX.80°C

FULL STEP 2 PHASE-Ex.,WHEN FACING MOUNTING END (X)

STEP	A+	B+	A-	B-
1	+	+	-	-
2	-	+	+	-
3	-	-	+	+
4	+	-	-	+

DIMENSIONS ARE IN MILLIMETERS.
 TOLERANCES AS BELOW:
 DECIMALS ANGLES
 X ±0.5 ±2°
 X.X ±0.25
 X.XX ±0.13



THIS DOCUMENT SHALL NOT BE REPRODUCED NOR SHALL THE INFORMATION CONTAINED HEREIN BE USED BY OR DISCLOSED TO OTHERS UNLESS EXPRESSLY AUTHORIZED IN BY WRITING STEPPERONLINE.

SIGNATURE		DATE
DRN	MYX	8.1.2025
APVD	ZPJ	8.1.2025

STEPPERONLINE®

STEPPER MOTOR

23HS30-2804S

REV.	0	SCALE	2:3	DWG NO.	A1214
------	---	-------	-----	---------	-------