

STEPPERONLINE®

User Manual for Integrated Stepper Motor **ESS24-30**

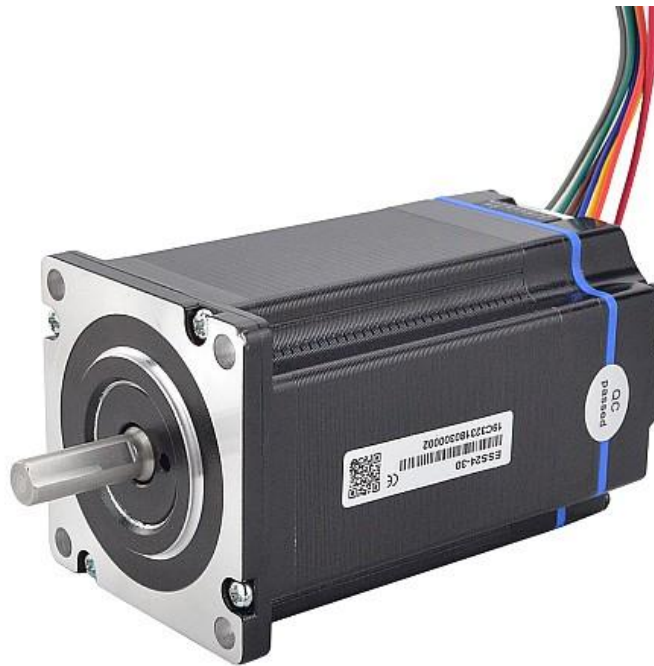

Designed by STEPPERONLINE®

©2020 All Rights Reserved

Address: 15-4, #799 Hushan Road, Jiangning, Nanjing, China

Tel: 0086-2587156578

Web: www.omc-stepperonline.com

Sales: sales@stepperonline.com

Support: technical@stepperonline.com

Attention: Please read this manual carefully before using the motor!

1. Introduction

The ESS24 series integrated motor adopts a new generation of 32-bit DSP control technology and power angle control technology. The speed can reach up to 3000rpm, and the high-speed torque attenuation is much lower than that of ordinary open-loop drives, which can greatly improve the high speed of the stepper motor. performance and torque utilization, effectively reducing motor heat and vibration, thereby improving the machine's processing efficiency and accuracy..

The use of load-based current control technology can effectively reduce motor heating and extend motor service life. The built-in position and alarm output signals of the driver facilitate monitoring and control by the host computer. The position out-of-tolerance alarm function ensures the safe operation of the processing equipment.

2. Features

- Next generation 32-bit DSP technology
- Pulse input frequency up to 200KHz
- Small torque attenuation, speed up to 3000RPM
- Built-in alarm output facilitates monitoring and control
- Pulse/direction (PU / DR) control
- Voltage range: DC24V ~ 50V
- Over-voltage, under-voltage and over-current protection
- Excellent high speed performance and rigidity, combined with advantages of servo motor and stepper motor
- Driver and motor integrated, simple wiring
- Intelligently adjusts current to reduce vibration, noise and heat, increasing efficiency by 35%

3. Specifications

3.1. Electrical Specifications

Parameters	ESS24-30			
	MIN	TYP	MAX	UNIT
Output Current	1.8	-	4.0	A
Input Voltage	24	36	50	VDC
Logic Signal Current	10	10	50	mA
Logic Signal Voltage	-	5	5	V
Pulse Input Frequency	0	-	200	kHz
Isolation Resistance	100	-	-	MΩ

Parameters	UNIT	ESS24-30
No. of Phase	--	2
Step Angle	°	1.8
Motor length	mm	86
Holding Torque	N.m	3.0
Rated Current	A	5.0
Resistance/Phase	Ω	0.43
Inductance/Phase	mH	2.0
Rotor Inertia	g.cm ²	690
Insulation Class	--	B
Operating Temperature	°c	0 ~ 55

3.2. Operating Environment

Cooling	Natural cooling	
Working Environment	Workplace	Keep away from other heating equipment, avoid dust, oil mist, corrosive gases, strong vibration places, flammable gases and conductive dust are prohibited
	Temperature	0°c ~ 50°c
	Humidity	40 - 90%RH(no condensation, no frosting)
	Vibration	10 ~ 55Hz/0.15mm
Storage Temperature	-20°c ~ +80°c	

4. Installation Dimensions(unit: mm)

Front view

Side view

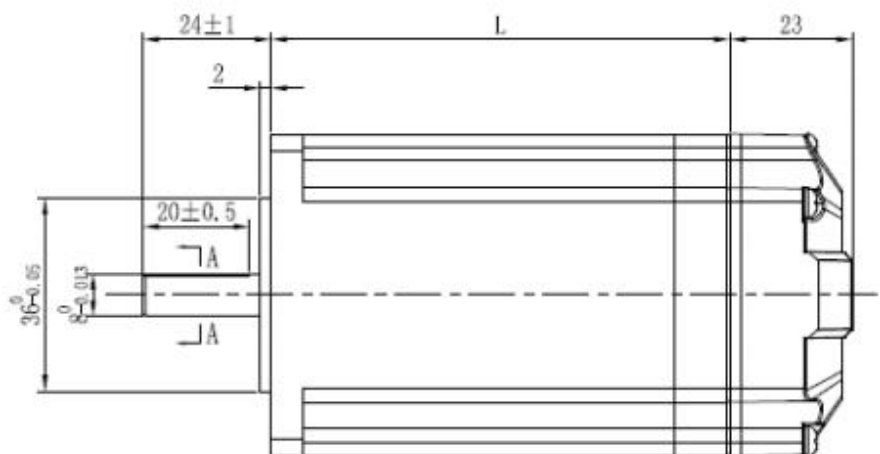
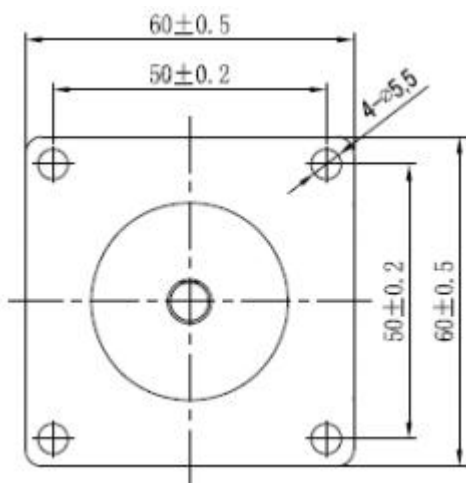

Model	L(mm)
ESS24-30	86

5. Driver Ports and Wiring

5.1. Wiring Diagram

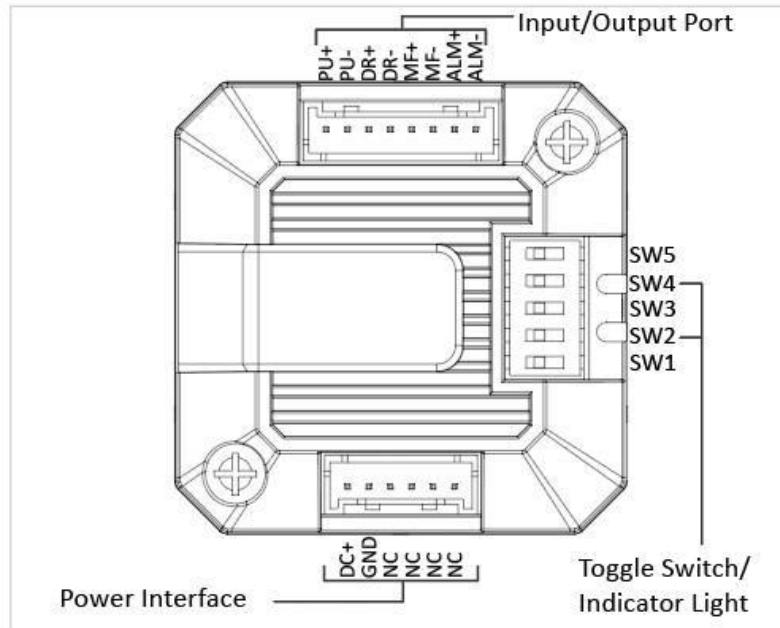

5.2. Port Definition

5.2.1. Indicator Light

Light Color	Code	Function	Description
Green	PWR	Power Indicator	When the power is on, the indicator light is always on
Red	ALM	Alarm Indicator	When overcurrent occurs, the indicator light flashes once in a cycle; when overvoltage occurs, the indicator light flashes twice in a cycle; when undervoltage occurs, the indicator light flashes three times in a cycle; when out of tolerance, the indicator light flashes five times in a cycle

5.2.2. Input/Output Ports

Function	Specification	Remark
VDC+	Supply voltage	VDC: 24V ~ 50V
GND	Ground	
PU+	Pulse input signal+	Signal power supply: 5V ~ 24V, >5V, add a current-limiting resistance
PU-	Pulse input signal-	
DR+	Direction input signal+	
DR-	Direction input signal-	
MF+	Motor freed signal+	
MF-	Motor freed signal-	
ALM+	Alarm output signal+	Over-current, over-voltage, position following error alarm output
ALM-	Alarm output signal-	
-	NC	NC

5.2.3. DIP Switch

Pin	Code	Name	Function
1	SW1	DIP switch	SW1: Motor rotation direction setting
2	SW2		
3	SW3		SW2-5: Microstep settings
4	SW4		
5	SW5		

5.3. Control Signal Connection

5.3.1. Input Signal

All signals are optically isolated to ensure reliable conduction of the built-in high-speed optocoupler, and the current driving capability of the control signal is required to be at least 10mA. The optocoupler current-limiting resistor has been connected in series inside the driver. When the input signal voltage is higher than 5V, it can be An external series resistor R is required for current limiting.

Selection of resistance value of current limiting resistor R:

When the controller/actuator signal output level is

+5V: R1=0, R2=0

At +12V: R1=510Ω, R2=820Ω

At +24V: R1=1.2KΩ, R2=1.8KΩ

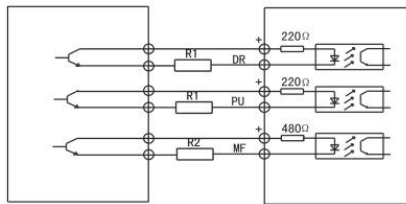

Controller Driver
Differential Connection

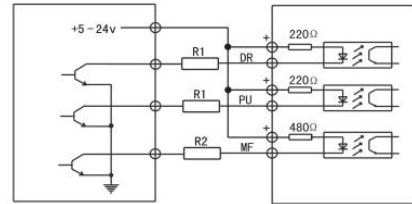

Controller Driver
Independent NPN Connection

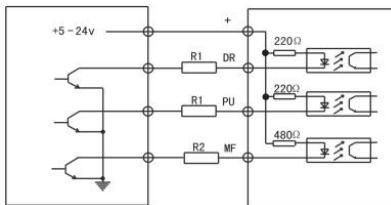

NPN Connection

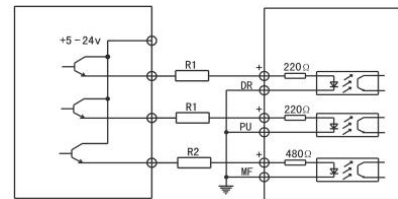

Independent PNP Connection

5.3.2. Output Signal

The driver output signal is output through optocoupler isolation, and the driving current is 50mA.

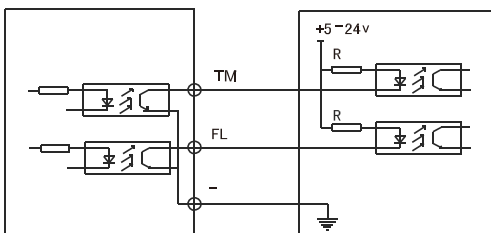

Driver Actuator
PNP Connection

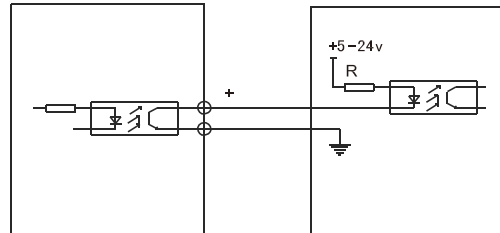

Driver Actuator
Independent Connection

5.3.3. Input Signal Waveform Timing Diagram

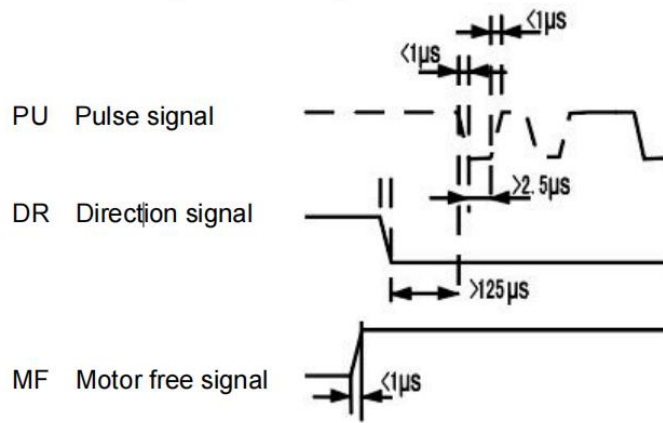

5.4. DIP Switch Setting

5.4.1. Motor Rotation Direction Setting





SW1	Motor Rotation Direction
OFF	CW
ON	CCW

5.4.2. Microstep Setting

PU/Rev	SW2	SW3	SW4	SW5
400	ON	ON	ON	ON
800	OFF	ON	ON	ON
1600	ON	OFF	ON	ON
3200	OFF	OFF	ON	ON
6400	ON	ON	OFF	ON
12800	OFF	ON	OFF	ON
25600	ON	OFF	OFF	ON
51200	OFF	OFF	OFF	ON
1000	ON	ON	ON	OFF
2000	OFF	ON	ON	OFF
4000	ON	OFF	ON	OFF
5000	OFF	OFF	ON	OFF
8000	ON	ON	OFF	OFF
10000	OFF	ON	OFF	OFF
20000	ON	OFF	OFF	OFF
40000	OFF	OFF	OFF	OFF

SW1: Motor rotation direction OFF=CW , ON=CCW

5.5. Fault Diagnosis

Fault Code	Cause of Fault	ALM Output	Operating
Err1: 0x01	Over current or phase-to-phase short circuit		Clear enable/Brown-Out reset
Err2: 0x02	Power supply voltage is too high		Lock Shaft/Voltage returns to normal
Err3: 0x03	Power supply voltage is too low		Lock Shaft/Voltage returns to normal
Err5: 0x05	Out of tolerance		Clear enable/Brown-Out reset