

STEPPERONLINE®

User Manual

DM860Y

Open Loop Stepper Driver

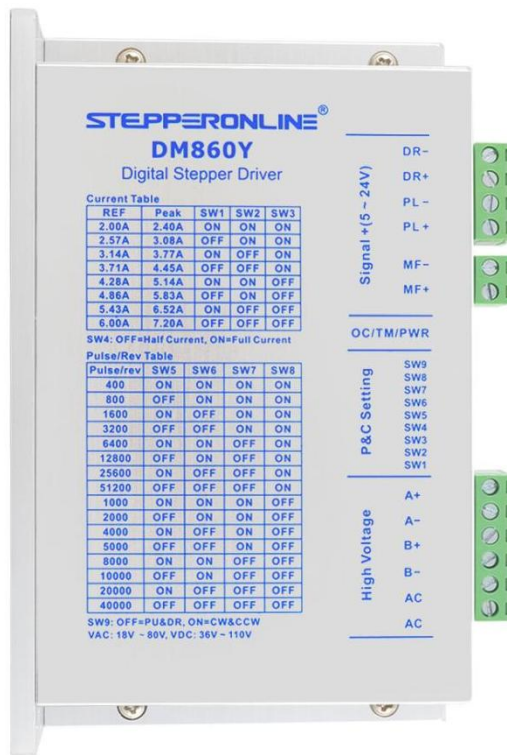

Pulse type open loop stepper driver instruction manual

Version: V1.0

©2025 All Rights Reserved

Address: 15-4, #799 Hushan Road, Jiangning, Nanjing, China

Tel: 0086-2587156578

Web: www.omc-stepperonline.com

Sales: sales@stepperonline.com

Support: technical@stepperonline.com

Catalogue

Catalogue	2
Revision history	1
Introduction	2
Chapter 1 Overview	3
1.1 Product introduction	3
1.2 Application field	3
Chapter 2 Performance Indicators	4
2.1 Electrical characteristic	4
2.2 Using environment	4
Chapter 3 Installation	5
3.1 Mounting dimension	5
3.2 Installation Methods	5
Chapter 4 Driver Ports and Wiring	6
4.1 Wiring diagram	6
4.2 Port Definition	7
4.2.1 Status indicator light	7
4.2.2 Control signal input port	7
4.2.3 Power input and motor port	7
4.2.4 Dip switch	8
4.3 Input/output port operation	8
4.4 Signal input timing diagram	9
Chapter 5 Drive operation parameter Settings	10
5.1 Driver current setting	10
5.2 Drive subdivision Settings	10
5.3 Lock current	11
5.4 MF motor release signal	11
Chapter 6 Driver Status Indicators	12
Chapter 7 General Troubleshooting methods	13

Revision history

Version	Description	Date	Remark
V1.0	First edition release	2024.11.30	

Introduction

Thank you for using this stepper drive.

Before using this product, be sure to read this manual carefully to understand the necessary safety information, precautions, and operation methods.

The wrong operation can lead to extremely serious consequences.

Statement

The design and manufacture of this product does not have the ability to protect personal safety from the threat of mechanical systems. Users are requested to consider safety protection measures during the design and manufacture of mechanical systems to prevent accidents caused by improper operation or abnormal products.

Due to product improvements, the contents of the manual are subject to change without notice.

Our company will not be responsible for any modification of the product by the user.

When reading, please note the following marks in the manual:



Remind you to pay attention to the main points in the text.



Indicates that improper operations may result in personal injury or equipment damage.

Chapter 1 Overview

1.1 Product introduction

DM860Y is a high performance stepper driver based on a new generation of digital control technology. The driver control mode is pulse control, and 4 dialing codes can be selected for 16 segments subdivision. Three-channel photoelectric isolation digital input, the driver supports motor parameter identification adaptive and phase memory function; In the internal use of similar servo control principle, unique circuit design, superior software algorithm processing can make the motor running smoothly at low speed, precise current control technology greatly reduces the motor heat, in the user expects low heat, low noise, high stability, high precision equipment application effect is particularly good.

- A new generation of 32-bit DSP control technology, high cost performance, good stability, superior noise, vibration performance;
- optical coupling isolated differential signal input, compatible with 5V/24V signal, can adapt to the signal requirements of different controllers;
- new motor parameter identification function, can identify the motor and given control parameters, play its best performance;
- adopts the latest resonance suppression algorithm, which has excellent stationarity in medium and low speed and low frequency subdivision;
- is equipped with 16 equal Angle constant torque subdivision, up to 51200 subdivision;
- The highest impulse response frequency up to 200KHz;When the stepping pulse stops more than 250ms, the motor current is halved;
- Voltage input range: AC18-80V/DC36-110V;

has the functions of over-voltage, under-voltage, over-current protection and detection;

1.2 Application field

Mainly used in engraving machine, laser equipment, labeling machine, electronic equipment, advertising equipment, packaging equipment.

Chapter 2 Performance Indicators

2.1 Electrical characteristic

Argument	DM860Y			
	Minimum value	Typical value	Maximum value	Unit
Continuous output current	0	-	8.4	A
Input supply voltage	24	48	110	Vdc
Logic input current	7	10	20	mA
Pulse frequency	0	-	200	kHz
Insulation resistance	50	-	-	MΩ

2.2 Using environment

Cooling mode	Natural cooling	
Use environment	Use occasion	Try to stay away from other heating equipment, avoid dust, oil mist, corrosive gas, strong vibration places, flammable gas and conductive dust are prohibited
	Temperature	0°C~50°C
	Humidity	40—90%RH (non-condensation)
	Vibration	10~55Hz/0.15mm
Storage temperature	-20°C~+70°C	

Chapter 3 Installation

3.1 Mounting dimension

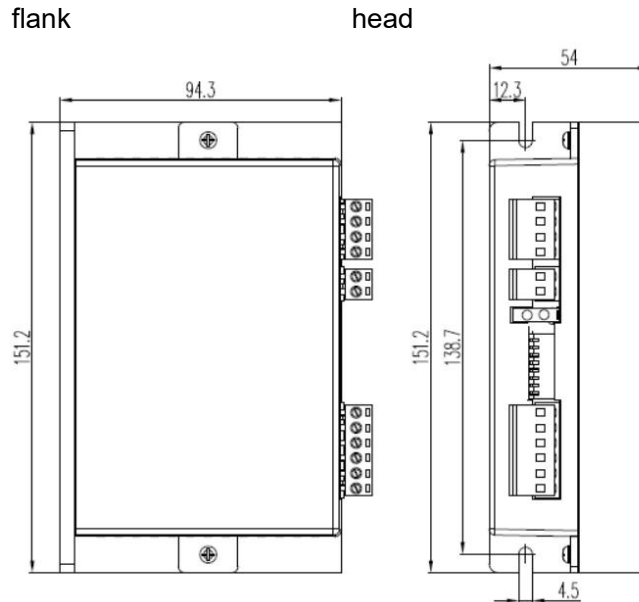

Installation size drawing (unit: mm)

3.2 Installation Methods

When installing the driver, please use the upright side installation to form strong air convection on the driver surface; If necessary, install a fan close to the driver to force the heat to dissipate to ensure that the driver works within the reliable operating temperature range (the reliable operating temperature of the driver is usually within 50°C, and the operating temperature of the motor is within 80°C).

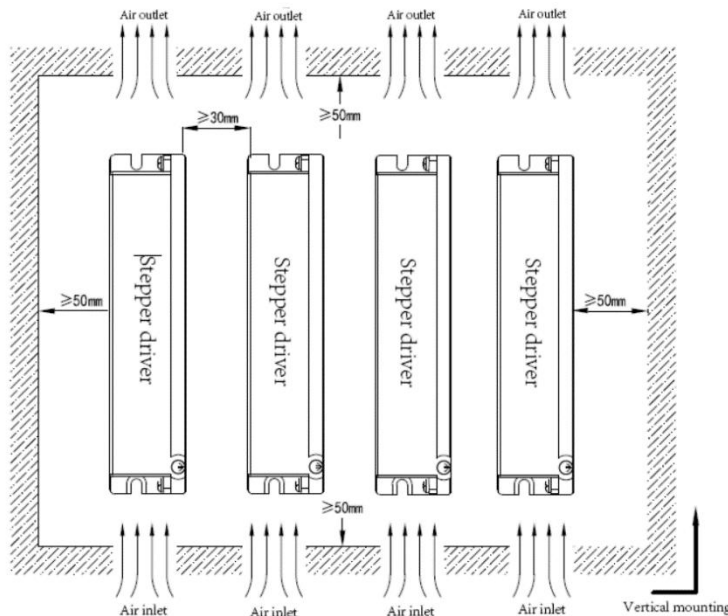

Chapter 4 Driver Ports and Wiring

4.1 Wiring diagram

Use the DM860Y drive according to the interface diagram:

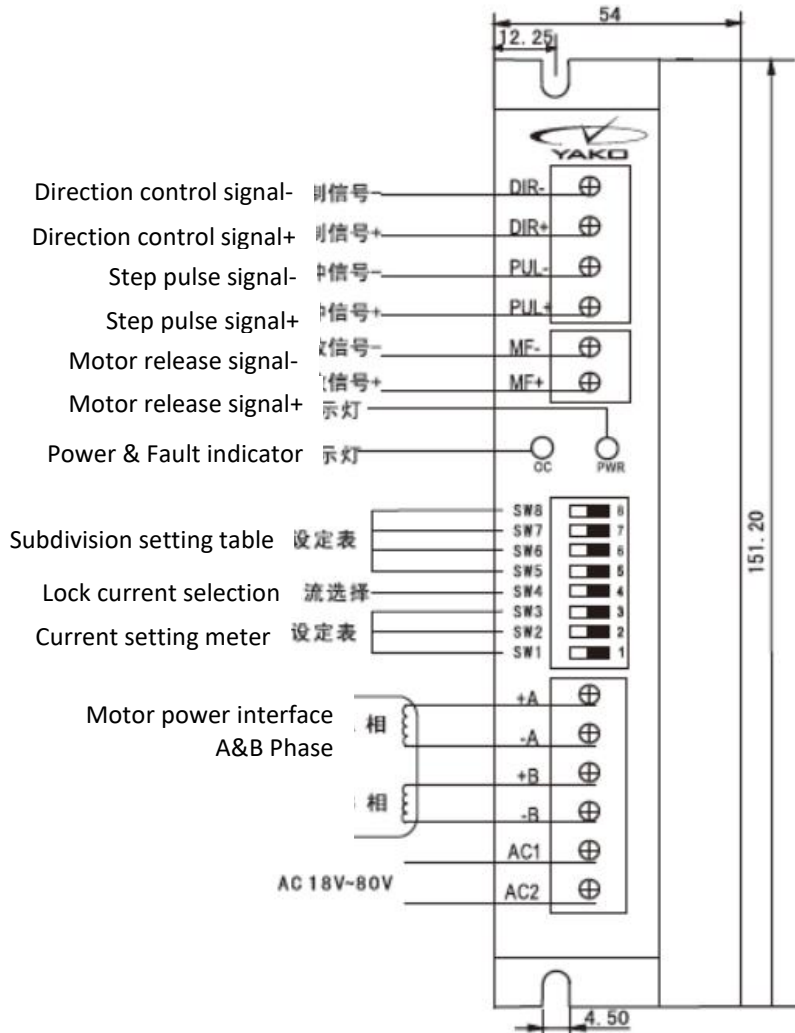

Attention!

- The personnel involved in wiring must have professional ability.
- No live wiring.
- The wiring can only be carried out after the installation is firm.
- Do not connect the power supply wrong, the input voltage should not exceed 80VAC/110VDC.

4.2 Port Definition

4.2.1 Status indicator light

Color	Name	Features
Green	Power indicator light	When the power is on, the green indicator lights up.
Red	Fault indicator light	Drive overcurrent: Flash once Drive overvoltage:Flash twice Drive undervoltage:Flash three times

4.2.2 Control signal input port

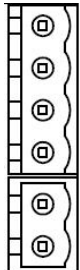
Port	Lead	Symbol	Feature	Annotation
	1	DIR-	Directional signal photoelectric isolation negative end	Used to change the direction of the motor.
	2	DIR+	Directional signal photoelectric isolation positive end	Direction signal input positive end, +5~24V input, higher than 24V need to connect to the current limiting resistance.
	3	PUL-	Pulse signal photoelectric isolation negative end	The falling edge is effective, and the motor starts to run when the pulse changes from high to low.
	4	PUL+	Pulse signal photoelectric isolation positive end	Connect to signal power supply, +5~24V input, higher than 24V need to connect to current limiting resistance.
	5	MF-	Release signal photoelectric isolation negative end	When effective, turn off the motor coil current, and the motor is in a free state.
	6	MF+	Release signal photoelectric isolation positive end	Connect to signal power supply, +5~24V input, higher than 24V need to connect to current limiting resistance.

4.2.3 Power input and motor port

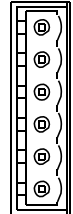
Port	Lead	Symbol	Name	Function
	1	A+	Motor interface	Two phase stepper motor connector
	2	A-		
	3	B+		
	4	B-		
	5	~AC	Power interface	VAC 20-80V VDC 30-110V
	6	~AC		

4.2.4 Dip switch

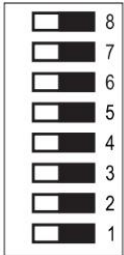
Port	Lead	Symbol	Function
	1	SW1	Current value setting
	2	SW2	
	3	SW3	
	4	SW4	Lock motor current Settings
	5	SW5	Subdivision setting
	6	SW6	
	7	SW7	
	8	SW8	

4.3 Input/output port operation

The DM860Y driver has three digital inputs, photoelectric isolation, and the signal supports 5V-24V input. When the input signal is higher than 24V, the series current limiting resistance is required at the signal input end. The specific wiring diagram is as follows:
input:

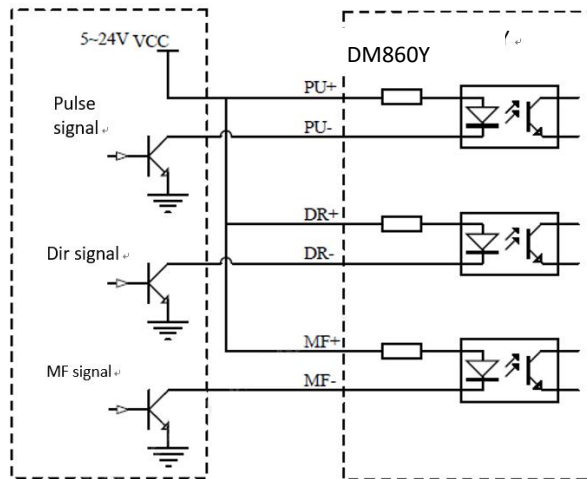

Common positive connection

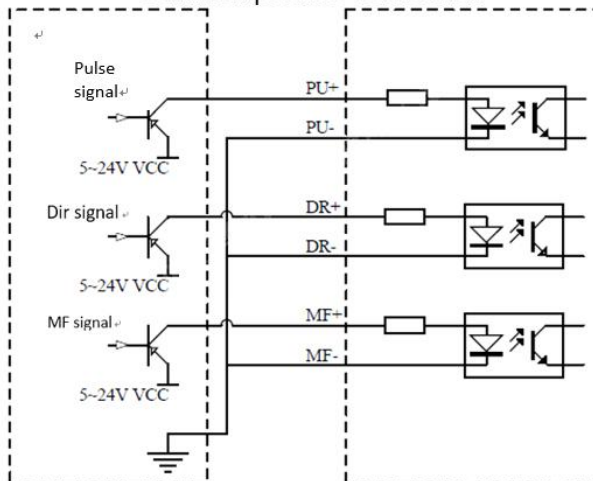

Common negative connection

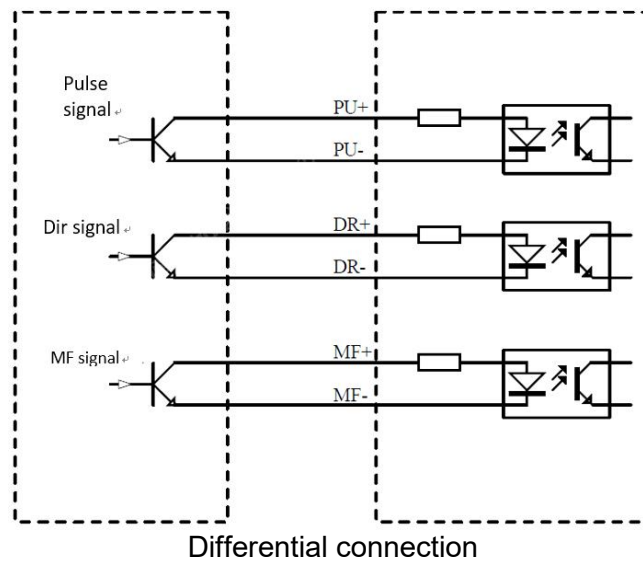

4.4 Signal input timing diagram

DM860Y driver In order to avoid abnormal operation of the driver control motor, please refer to the following diagram for the timing diagram of the input signal:

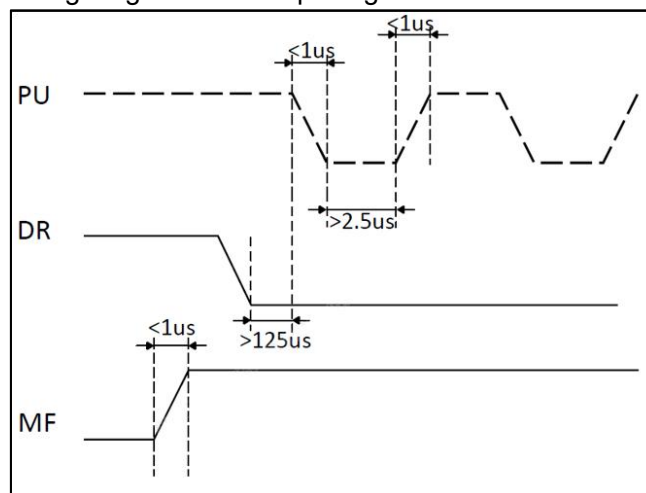

Chapter 5 Drive operation parameter Settings

The DM860Y stepper motor driver uses a 6-bit dip switch to set the driver current and subdivision. The specific Settings are as follows:

5.1 Driver current setting

The DM860Y driver sets the peak output current or RMS value through SW1, SW2, SW3 dip switches.

Normally, the current is set to the rated current of the motor. If your system has high heating requirements, you can appropriately reduce the current to reduce the heat of the motor, but the output torque of the motor will be reduced at the same time. If you do not require continuous operation of the motor, you can appropriately increase the running current to obtain greater torque.

DM860Y Ammeter of current: (unit:A)

Current RMS	Current PEAK	SW1	SW2	SW3
2.00	2.40	ON	ON	ON
2.57	3.08	OFF	ON	ON
3.14	3.77	ON	OFF	ON
3.71	4.45	OFF	OFF	ON
4.28	5.14	ON	ON	OFF
4.68	5.83	OFF	ON	OFF
5.43	6.52	ON	OFF	OFF
6.00	7.20	OFF	OFF	OFF

Remark: Current RMS is the effective value, current Peak is the peak value of current

5.2 Drive subdivision Settings

DM860Y driver through SW4, SW5, SW6 dial switches to set the corresponding subdivision, as shown in the table below:

Subdivision	PU/rve	SW5	SW6	SW7	SW8
2	400	ON	ON	ON	ON
4	800	OFF	ON	ON	ON
8	1600	ON	OFF	ON	ON
16	3200	OFF	OFF	ON	ON
32	6400	ON	ON	OFF	ON
64	12800	OFF	ON	OFF	ON
128	25600	ON	OFF	OFF	ON
256	51200	OFF	OFF	OFF	ON
5	1000	ON	ON	ON	OFF
10	2000	OFF	ON	ON	OFF
20	4000	ON	OFF	ON	OFF
25	5000	OFF	OFF	ON	OFF
40	8000	ON	ON	OFF	OFF
50	10000	OFF	ON	OFF	OFF
100	20000	ON	OFF	OFF	OFF
200	40000	OFF	OFF	OFF	OFF

5.3 Lock current

The DM860Y driver uses the SW4 dip switch to set the percentage of lock current when the motor is stationary, as follows:

SW4	Percentage of lock current
OFF	Half flow lock
ON	Full flow lock

5.4 MF motor release signal

MF signal	Running state
effective	Machine without lock
Invalid	Locking machine

Chapter 6 Driver Status Indicators

The DM860Y driver has an alarm prompt. After the driver alarms, the alarm indicator state indicates the alarm information of the driver. The specific alarm information is shown in the following table.

Fault information	ALM light	Resetting
Overcurrent or interphase short circuit	Flash once	Power-off reset
Overvoltage of supply	Flash twice	Automatic restoration of standard voltage
The power supply voltage is too low.	Flash Three times	Automatic restoration of standard voltage

Chapter 7 General Troubleshooting methods

Phenomenon	Possible situation	Solution measure
Motor failure	The power light is off	Check the power supply circuit. The power supply is normal
	The motor locks the shaft but does not turn	The IO signal is weak and the signal current is increased
	Too little speed	Selection speed
	Whether the release signal MF is connected	Disconnect the MF signal
	Instruction input error	Check whether the upper computer has a switch output
Motor direction error	Motor reversal	Replace motor wiring sequence or adjust instruction direction
	The motor line has a break	Check whether the cable is in poor contact
	The motor has only one direction	Input port damage
The alarm indicator light is on	The motor wire is connected incorrectly	Check the wiring
	The voltage is too high or low	Check power supply
	The motor or drive is damaged	Replace the motor or drive
Wrong position or speed	Signal interference	Eliminate interference, reliable grounding
	Instruction input error	Check the upper computer instructions to ensure correct output
	Speed setting error	Check the DIP switch status and connect it correctly
	Motor tripping	Check whether the command speed is too large and the motor selection is small
The driver terminal is burned out	Short-circuit between terminals	Check the power polarity or external short circuit
	The internal resistance between terminals is too large	Check whether excess solder is added to the wire and wire connection to form tin pellets
Motor stalling	The acceleration and deceleration time is too short	Reduce the command acceleration or increase the driver filter parameter
	Motor torque too small	Select high torque motor
	Heavy load	Check the load weight and quality, adjust the mechanical structure
	Too little current	Check dip switches to increase the output current of the driver