

STEPPERONLINE®

User Manual

CL86Y

Closed Loop Stepper Driver

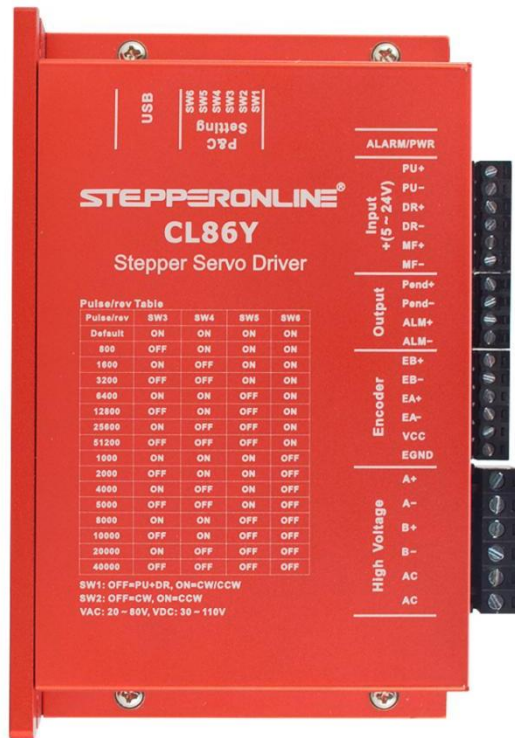

Pulse type close loop stepper driver instruction manual

Version: V1.0

©2025 All Rights Reserved

Address: 15-4, #799 Hushan Road, Jiangning, Nanjing, China

Tel: 0086-2587156578

Web: www.omc-stepperonline.com

Sales: sales@stepperonline.com

Support: technical@stepperonline.com

Catalogue

Catalogue	2
Revision history	1
Introduction	2
Chapter 1 Overview	3
1.1 Product introduction	3
1.2 Application field	3
Chapter 2 Performance Indicators	4
2.1 Electrical characteristic	4
2.2 Using environment	4
Chapter 3 Installation	5
3.1 Mounting dimension	5
3.2 Installation Methods	5
Chapter 4 Driver Ports and Wiring	6
4.1 Wiring diagram	6
4.2 Port Definition	7
4.2.1 Status indicator light	7
4.2.2 Drive dip Settings	7
4.2.3 Power input and motor port	8
4.2.4 Power input and motor port	8
4.2.5 Encoder input port	8
4.3 Input/output port operation	9
4.3.1 input signal:	9
4.3.2 output signal:	10
4.4 Signal input timing diagram	10
Chapter 5 Driver Status Indicators	12
Chapter 6 General Troubleshooting methods	13

Revision history

Version	Description	Date	Remark
V1.0	First edition release	2024.11.30	

Introduction

Thank you for using this stepper drive.

Before using this product, be sure to read this manual carefully to understand the necessary safety information, precautions, and operation methods.

The wrong operation can lead to extremely serious consequences.

Statement

The design and manufacture of this product does not have the ability to protect personal safety from the threat of mechanical systems. Users are requested to consider safety protection measures during the design and manufacture of mechanical systems to prevent accidents caused by improper operation or abnormal products.

Due to product improvements, the contents of the manual are subject to change without notice.

Our company will not be responsible for any modification of the product by the user.

When reading, please note the following marks in the manual:



Remind you to pay attention to the main points in the text.



Indicates that improper operations may result in personal injury or equipment damage.

Chapter 1 Overview

1.1 Product introduction

CL86Y adopts a new generation of 32-bit DSP control technology and power angle control technology, the maximum speed can reach 3000rpm, and the high-speed torque attenuation is far lower than that of the ordinary open-loop driver, which can greatly improve the high-speed performance and torque of the stepper motor, it can effectively reduce the heating and vibration of the motor, thus improving the processing efficiency and accuracy of the machine. The driver adopts load-based current control technology, which can effectively reduce motor heat and prolong motor service life. The built-in position and alarm output signals of the driver are convenient for the upper computer to monitor and control. Position out of tolerance alarm function guarantee.

- The current size is intelligently adjusted according to the load condition
- Can drive 24/34 series stepper motor.
- The optocoupler isolates the differential signal input
- The impulse response frequency is up to 200KHz.
- Voltage input range: AC18-80V/DC24-110V;
- With over current, over voltage, under voltage, position over error protection

1.2 Application field

This product is suitable for a variety of large automation equipment and instrument applications. For example: engraving machine, special industrial sewing machine, stripping machine, marking machine, cutting machine, laser phototypesetting, plotter, CNC machine tools and other automation equipment and instruments.

Chapter 2 Performance Indicators

2.1 Electrical characteristic

argument	CL86Y			
	Minimum value	Typical value	Maximum value	Unit
Continuous output current	0.6	-	7.2	A
Input supply voltage	20.0	-	80.0	Vdc
Logic input current	7.0	-	20.0	mA
Pulse frequency	-	-	200	kHz
Insulation resistance	500	-	-	MΩ

2.2 Using environment

Cooling mode	Natural cooling	
Use environment	Use occasion	Try to stay away from other heating equipment, avoid dust, oil mist, corrosive gas, strong
	Temperature	0°C~50°C
	Humidity	40—90%RH (non-condensation)
	Vibration	10~55Hz/0.15mm
Storage temperature	-20°C~+70°C	

Chapter 3 Installation

3.1 Mounting dimension

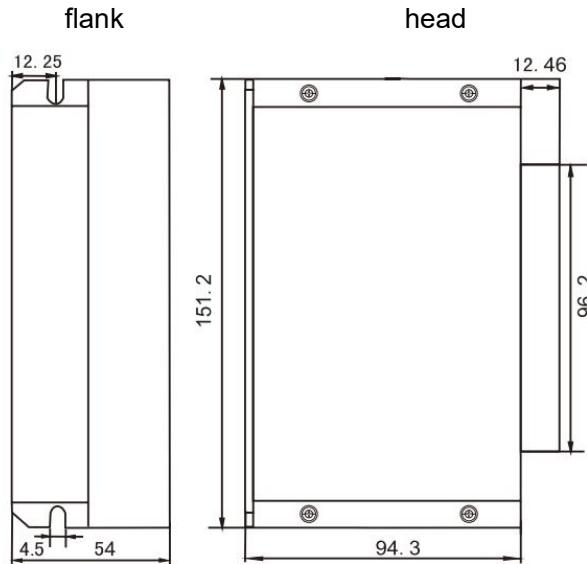

Installation size drawing (unit: mm)

3.2 Installation Methods

When installing the driver, please use the upright side installation to form strong air convection on the driver surface; If necessary, install a fan close to the driver to force the heat to dissipate to ensure that the driver works within the reliable operating temperature range (the reliable operating temperature of the driver is usually within 50°C, and the operating temperature of the motor is within 80°C).

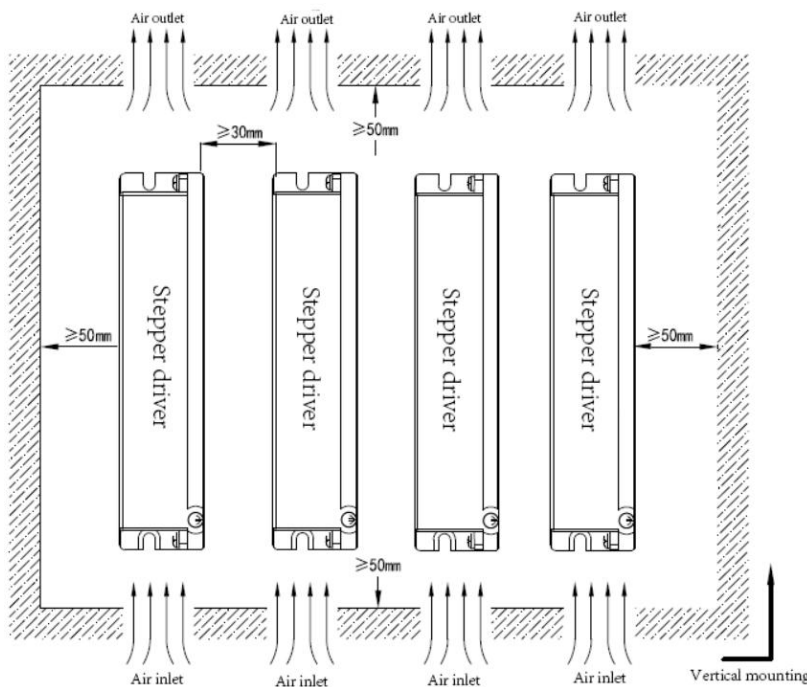

Chapter 4 Driver Ports and Wiring

4.1 Wiring diagram

Use the CL86Y drive according to the interface diagram:

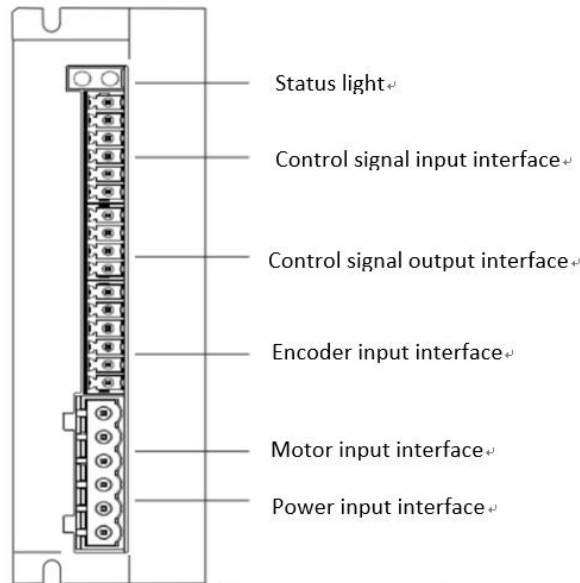

Schematic diagram of the side wiring of the driver

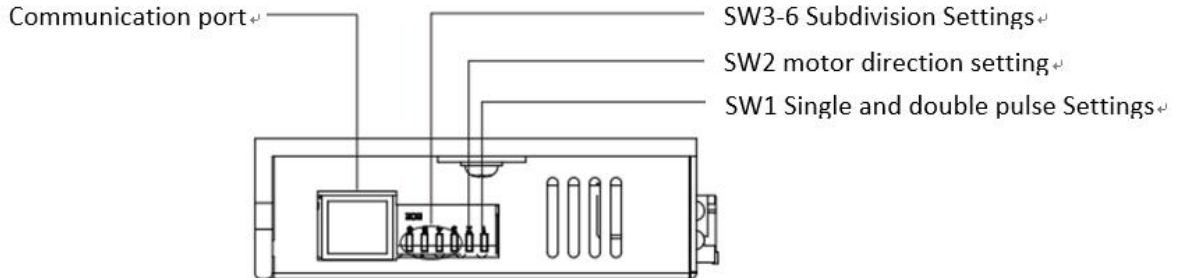

Schematic diagram of the top wiring of the drive



Attention!

- The personnel involved in wiring must have professional ability.
- No live wiring.
- The wiring can only be carried out after the installation is firm.
- Do not connect the power supply wrong, the input voltage should not exceed 80VAC/110VDC.

4.2 Port Definition

4.2.1 Status indicator light

Color	Name	Features
Green	Power indicator light	When the power is on, the green indicator lights up.
Red	Fault indicator light	Drive overcurrent: flash once Drive overvoltage: flash twice Drive undervoltage: flash three times Drive phase error: flash four times Drive overtolerance: flash five times Drive encoder error: flash six times

4.2.2 Drive dip Settings

SW1-SW2 is the basic function setting of the driver. Single and double pulse and rotation direction can be set respectively, as shown in the following table

Serial number	Dip code	function	Dip status	Set content
1	SW1	Single and double pulse Settings	ON	CW&CCW
			OFF	PU&DR
2	SW2	Motor rotation direction setting	ON	CCW
			OFF	CW

SW3-SW6 can set the drive subdivision, four dip switches a total of 16 gear, respectively set 400-51200 a total of 16 file subdivision, as shown in the following table:

DIP	Default (400)	800	1600	3200	6400	12800	25600	51200	1000	2000	4000	5000	8000	10000	20000	40000
SW3	ON	OFF	ON	OFF	ON	OFF	ON	OFF	ON	OFF	ON	OFF	ON	OFF	ON	OFF
SW4	ON	ON	OFF	OFF	ON	ON	OFF	OFF	ON	ON	OFF	OFF	ON	ON	OFF	OFF
SW5	ON	ON	ON	ON	OFF	OFF	OFF	OFF	ON	ON	ON	ON	OFF	OFF	OFF	OFF
SW6	ON	ON	ON	ON	ON	ON	ON	ON	OFF	OFF	OFF	OFF	OFF	OFF	OFF	OFF

4.2.3 Power input and motor port

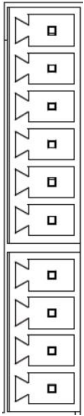
port	lead	symbol	feature	annotation
	1	PU+	Pulse signal input positive end	Digital input and output signals, +5V-+24V can be driven (higher than 5V need to be connected to the current limiting resistance), support common negative or common positive connection
	2	PU-	Pulse signal input negative end	
	3	DR+	Direction signal input positive end	
	4	DR-	Direction signal input negative end	
	5	MF+	Enable signal input positive end	Invalid (high level) turn off the motor coil current, the motor is in the free state and the alarm signal is cleared
	6	MF-	Enable signal input negative end	
	7	PEND+	Position signal output positive end	When the driver completes the given pulse, the position signal is effective (output optocoupler conduction).
	8	PEND-	Position signal output negative end	
	9	ALM+	Alarm signal output positive end	Over current, over voltage, under voltage or out of the alarm, the alarm signal is valid
	10	ALM-	Alarm signal output negative end	

4.2.4 Power input and motor port

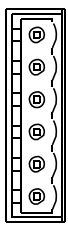
port	lead	symbol	name	function
	1	A+	Motor interface	Two phase stepper motor connector
	2	A-		
	3	B+		
	4	B-		
	5	~AC	Power interface	VAC18-80V VDC24-110V
	6	~AC		

4.2.5 Encoder input port

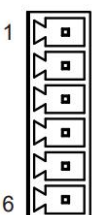
	lead	symbol	name	function
	1	EB+	Encoder B phase input positive/negative end	Encoder B channel positive input/negative input
	2	EB-		
	3	EA+	Encoder phase A input positive/negative end	Encoder A channel positive input/negative input
	4	EA-		
	5	VCC	Encoder power supply	Encoder 5V power supply
	6	EGND	Encoder GND	Encoder GND

4.3 Input/output port operation

The CL86Y driver has three digital inputs, photoelectric isolation, and the signal supports 5V-24V input. When the input signal is higher than 24V, the series current limiting resistance is required at the signal input end. The specific wiring diagram is as follows:

4.3.1 Input signal:

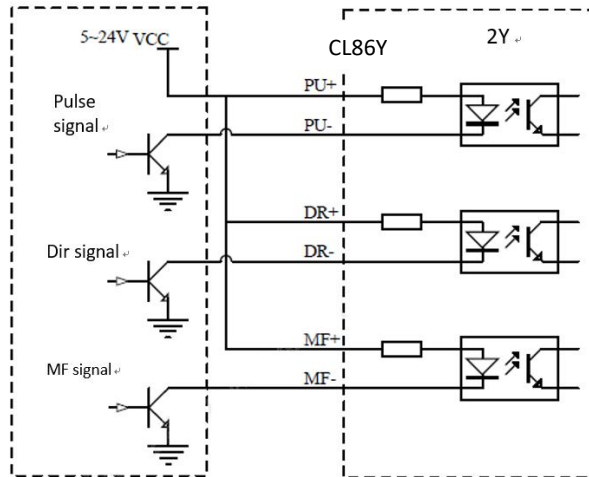

Common positive connection

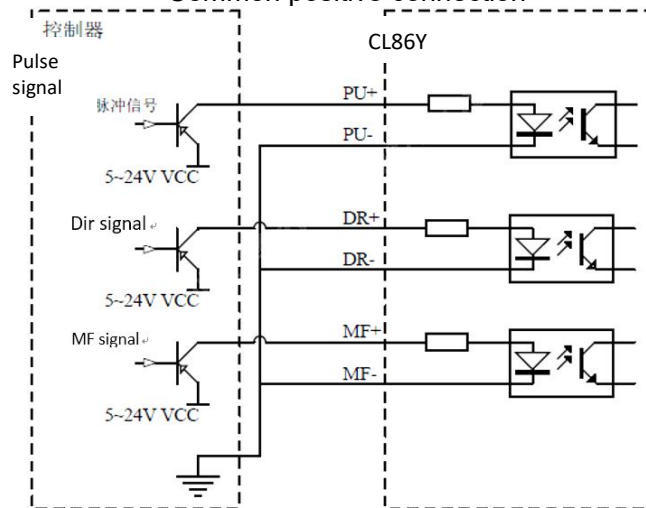

Common negative connection

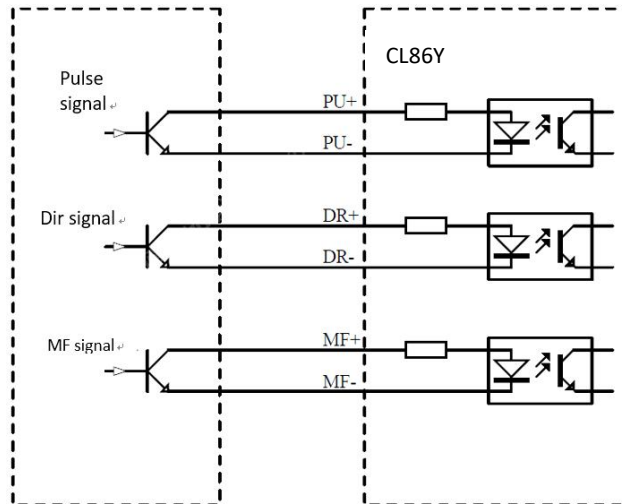

Differential connection

4.3.2 Output signal:

The driver output signal is isolated by an optocoupler and the drive current is max 50mA.

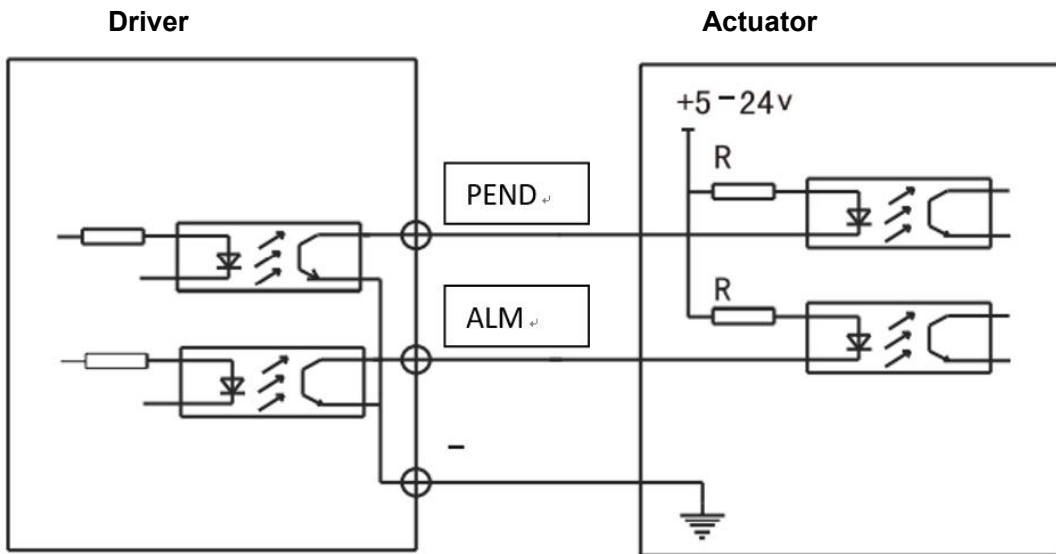

Common negative end connection

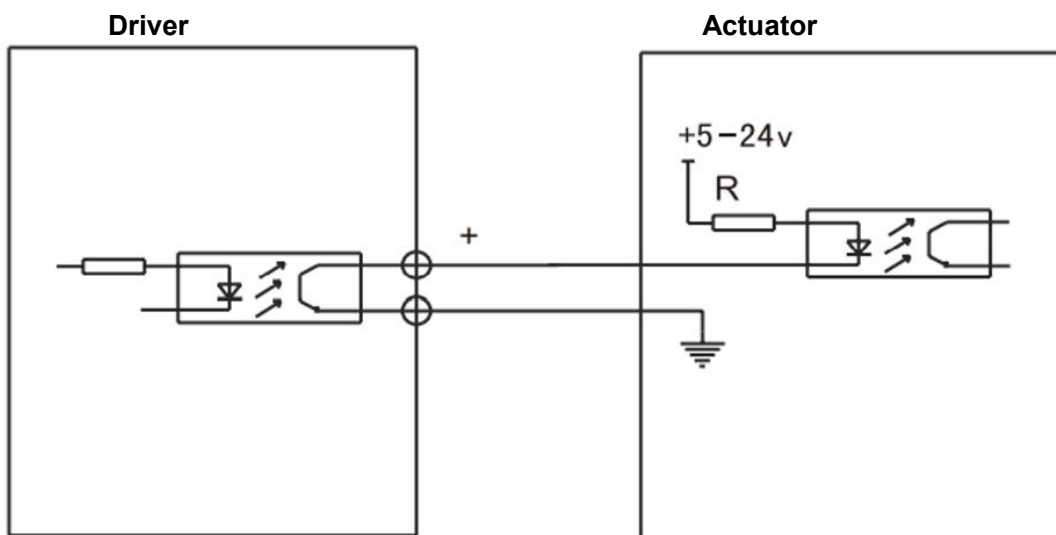

Independent termination method

4.4 Signal input timing diagram

CL86Y driver In order to avoid abnormal operation of the driver control motor, please refer to the following diagram for the timing diagram of the input signal:

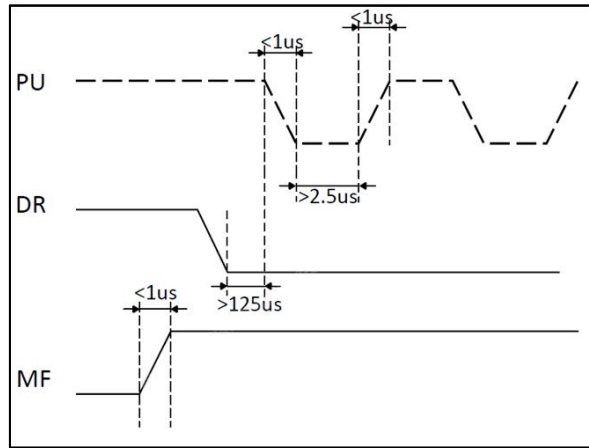

Chapter 5 Driver Status Indicators

The CL86Y driver has an alarm prompt. After the driver alarms, the alarm indicator state indicates the alarm information of the driver. The specific alarm information is shown in the following table.

Fault information	ALM Pilot lamp	Resetting
Overcurrent or interphase short circuit	Flash once	Power-off reset
Overvoltage of supply	Flash twice	Automatic restoration of standard voltage
The power supply voltage is too low.	Flash Three times	Automatic restoration of standard voltage
The Drive phase error	Flash four times	Cables are connected correctly. Restart and restore
Drive overtolerance	Flash five times	Release/power-off reset or MF clear out alarm
Drive encoder error	Flash six times	Cables are connected correctly. Restart and restore

Chapter 6 General Troubleshooting methods

phenomenon	Possible situation	Solution measure
Motor failure	The power light is off	Check the power supply circuit. The power supply is normal
	The motor locks the shaft but does not turn	The IO signal is weak and the signal current is increased
	Too little speed	Selection speed
	Whether the release signal MF is connected	Disconnect the MF signal
	Instruction input error	Check whether the upper computer has a switch output
Motor direction error	Motor reversal	Replace motor wiring sequence or adjust instruction direction
	The motor line has a break	Check whether the cable is in poor contact
	The motor has only one direction	Input port damage
The alarm indicator light is on	The motor wire is connected incorrectly	Check the wiring
	The voltage is too high or low	Check power supply
	The motor or drive is damaged	Replace the motor or drive
Wrong position or speed	Signal interference	Eliminate interference, reliable grounding
	Instruction input error	Check the upper computer instructions to ensure correct output
	Speed setting error	Check the DIP switch status and connect it correctly
	Motor tripping	Check whether the command speed is too large and the motor selection is small
The driver terminal is burned out	Short-circuit between terminals	Check the power polarity or external short circuit
	The internal resistance between terminals is too large	Check whether excess solder is added to the wire and wire connection to form tin pellets
Motor stalling	The acceleration and deceleration time is too short	Reduce the command acceleration or increase the driver filter parameter
	Motor torque too small	Select high torque motor
	Heavy load	Check the load weight and quality, adjust the mechanical structure
	Too little current	Check dip switches to increase the output current of the driver