

CUSTOMER'S MODEL: NO MODEL  
 END COVER COLOR: BLACK

REV.	REVISION RECORD	BY	DATE
0	ORIGIN	MYX	8.1.2025

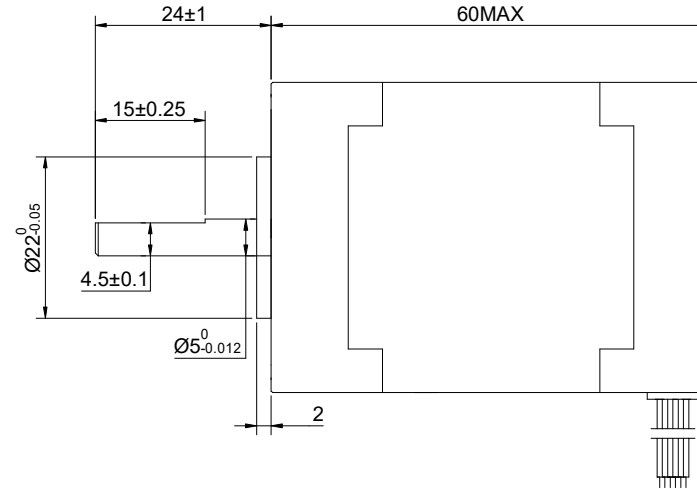

COMMENT:  
 1.DYNAMIC AXIAL LOAD: 10N MAX  
 2.DYNAMIC RADIAL LOAD @ SHAFT LENGTH 20mm: 21N MAX  
 3.TMBF 6000h OR MORE @ 24V/300RPM  
 4.INSULATION RESISTANCE (NORMAL TEMPERATURE AND HUMIDITY): 100 Mohm  
 5.DIELECTRIC STRENGTH 500VAC FOR 1MIN.(BETWEEN THE MOTOR COILS AND THE MOTOR CASE )

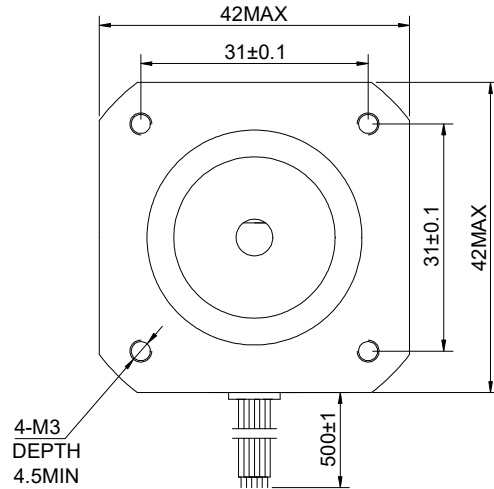

MOTOR CONNECTION			
PIN NO	BIPOLAR	LEADS	WINDING
1	A+	BLK	
2	A -	GRN	
3	B+	RED	
4	B -	BLU	
5	O+	YEL	
6	O-	WHT	

SPECIFICATION	CONNECTION	UNIPOLAR
AMPS/PHASE		1.20
RESISTANCE/PHASE(Ohms)@25°C		6.00±10%
INDUCTANCE/PHASE(mH)@1KHz		7.00±20%
HOLDING TORQUE(Nm)[lb-in]		0.65[5.75]
STEP ANGLE(°)		1.80
STEP ACCURACY(NON-ACCUM)		±5.00%
ROTOR INERTIA(g-cm <sup>2</sup> )		82.00
WEIGHT(Kg)[lb]		0.50[1.10]
AMBIENT TEMPERATURE		-10°C~50°C[14°F~122°F]
INSULATION CLASS		B 130°C[266°F]
TEMPERATURE RISE		MAX.80°C

FULL STEP 2 PHASE-Ex.,WHEN FACING MOUNTING END (X)					
STEP	A+	B+	A-	B-	O(O)
1	-	-			+
2		-	-		+
3			-	-	+
4	-			-	+

DIMENSIONS ARE IN MILLIMETERS.  
 TOLERANCES AS BELOW:  
 DECIMALS ANGLES  
 X ±0.5 ±2°  
 X.X ±0.25  
 X.XX ±0.13

THIRD ANGLE PROJECTION

THIS DOCUMENT SHALL NOT BE REPRODUCED NOR SHALL THE INFORMATION CONTAINED HEREIN BE USED BY OR DISCLOSED TO OTHERS UNLESS EXPRESSLY AUTHORIZED IN BY WRITING STEPPERONLINE.

SIGNATURE		DATE
DRN	MYX	8.1.2025
APVD	ZPJ	8.1.2025

**STEPPERONLINE®**

**STEPPER MOTOR**

**17HS24-1206S**

REV.	0	SCALE	1:1	DWG NO.	A0882
------	---	-------	-----	---------	-------