



## User Manual

# DM422IO

IO type open loop stepper driver instruction manual

Version: V1.0

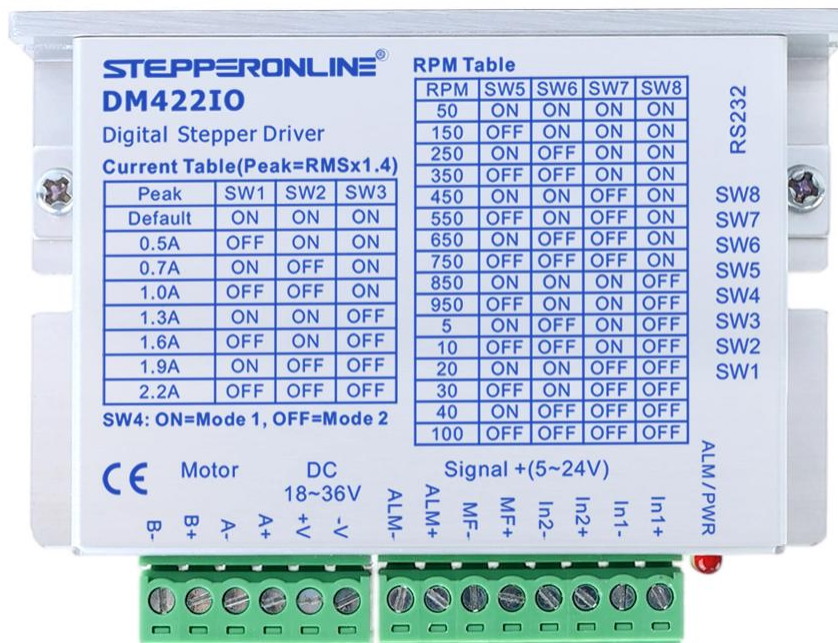

©2025 All Rights Reserved

Address: 15-4, #799 Hushan Road, Jiangning, Nanjing, China

Tel: 0086-2587156578

Web: [www.omc-stepperonline.com](http://www.omc-stepperonline.com)

Sales: [sales@stepperonline.com](mailto:sales@stepperonline.com)

Support: [technical@stepperonline.com](mailto:technical@stepperonline.com)

## Catalogue

Revision history .....	1
Introduction .....	2
Chapter 1 Overview .....	3
1.1 Product introduction .....	3
1.2 Peculiarity .....	3
1.3 Application field .....	3
Chapter 2 Performance Indicators .....	4
2.1 Electrical characteristic .....	4
2.2 Using environment .....	4
Chapter 3 Installation .....	5
3.1 Mounting dimension .....	5
3.2 Installation Methods .....	5
Chapter 4 Driver Ports and Wiring .....	6
4.1 Wiring diagram .....	6
4.2 Port Definition .....	7
4.2.1 Status indicator light .....	7
4.2.2 Control signal input port .....	7
4.2.3 Power input and motor port .....	8
4.2.4 Dip switch .....	8
4.3 Input/output port operation .....	8
4.3.1 input .....	8
4.3.2 Output .....	9
Chapter 5 Drive operation parameter Settings .....	10
5.1 Driver current setting .....	10
5.2 Drive subdivision Settings .....	10
5.3 Control mode setting .....	11
5.4 MF The motor releases a signal .....	11
Chapter 6 Driver Status Indicators .....	12
Chapter 7 General Troubleshooting methods .....	13

## Revision history

Version	Description	Date	Remark
V1.0	First edition release	2025.04.18	

## Introduction

Thank you for using this stepper drive.

Before using this product, be sure to read this manual carefully to understand the necessary safety information, precautions, and operation methods.

The wrong operation can lead to extremely serious consequences.

## Statement

The design and manufacture of this product does not have the ability to protect personal safety from the threat of mechanical systems. Users are requested to consider safety protection measures during the design and manufacture of mechanical systems to prevent accidents caused by improper operation or abnormal products.

Due to product improvements, the contents of the manual are subject to change without notice.

Our company will not be responsible for any modification of the product by the user.

When reading, please note the following marks in the manual:



Remind you to pay attention to the main points in the text.



Indicates that improper operations may result in personal injury or equipment damage.

# Chapter 1 Overview

## 1.1 Product introduction

DM422IO is a high-performance stepper driver based on a new generation of digital control technology. The control mode of the driver is spontaneous pulse speed control, 16 segments of speed can be selected by 4 dialing codes, and any speed can be set within the speed range by the host computer. Three-channel photoelectric isolation digital input, the driver supports motor parameter identification adaptive and phase memory function; In the internal use of similar servo control principle, unique circuit design, superior software algorithm processing can make the motor running smoothly at low speed, precise current control technology greatly reduces the motor heat, in the user expects low heat, low noise, high stability, high precision equipment application effect is particularly good.

## 1.2 Peculiarity

- New generation of 32-bit DSP control technology, high cost performance
- Three optical coupling isolated digital signal input, compatible with 5V/24V signal, support common negative and common positive connection mode
- With the latest resonance suppression algorithm, it has excellent stationarity at low and medium speed.
- Current control smooth, accurate, motor heating is small
- With 8 levels of current, 16 levels of speed optional
- Operating current, speed, acceleration and deceleration can be set in the PC debugging software
- Start-stop control supports two modes
- Adaptive identification of motor parameters
- Phase memory function
- The lock current can be set by the host computer, the default is to set the current 50%
- With over voltage, under voltage, over current, error equal protection function

## 1.3 Application field

Typical applications: mainly used for speed control, board machine, board machine, docking station, logistics transmission, moving load equipment, electronic equipment, lithium equipment, etc .

## Chapter 2 Performance Indicators

### 2.1 Electrical characteristic

Argument	DM422IO			
	Minimum value	Typical value	Maximum value	Unit
Continuous output current	0	-	2.2	A
Input supply voltage	18	24	36	Vdc
Logic input current	7	10	20	mA
Insulation resistance	50	-	-	MΩ

### 2.2 Using environment

Cooling mode	Natural cooling	
Use environment	Use occasion	Try to stay away from other heating equipment, avoid dust, oil mist, corrosive gas, strong vibration places, flammable gas and conductive dust are prohibited
	Temperature	0°C~50°C
	Humidity	40-90%RH (non-condensation)
	Vibration	10~55Hz/0.15mm
Storage temperature	-20°C~+70°C	

# Chapter 3 Installation

## 3.1 Mounting dimension

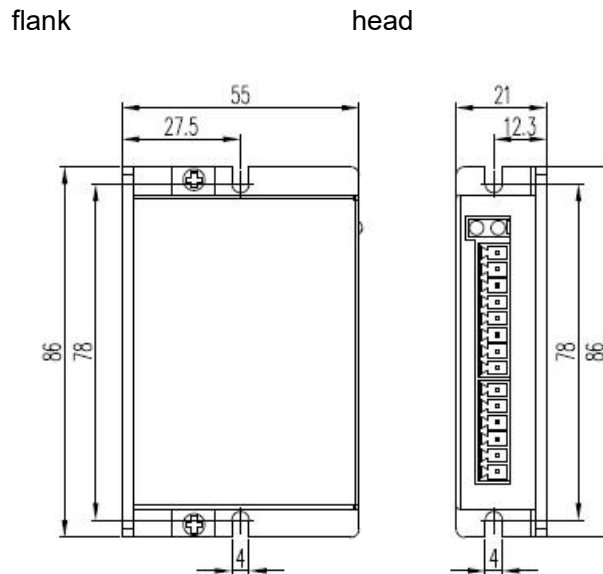

Mounting dimension drawing (unit: mm)

## 3.2 Installation Methods

When installing the driver, please use the upright side installation to form strong air convection on the driver surface; If necessary, install a fan close to the driver to force the heat to dissipate to ensure that the driver works within the reliable operating temperature range (the reliable operating temperature of the driver is usually within 50°C, and the operating temperature of the motor is within 80°C).

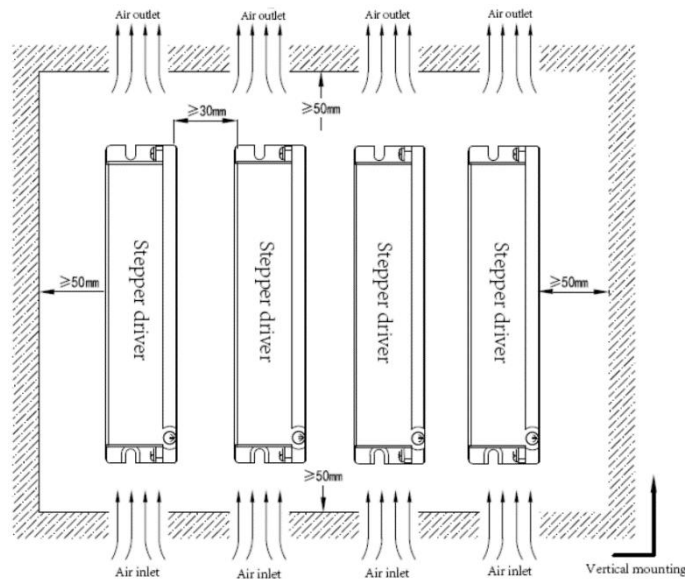

# Chapter 4 Driver Ports and Wiring

## 4.1 Wiring diagram

Use the DM422IO drive according to the interface diagram:

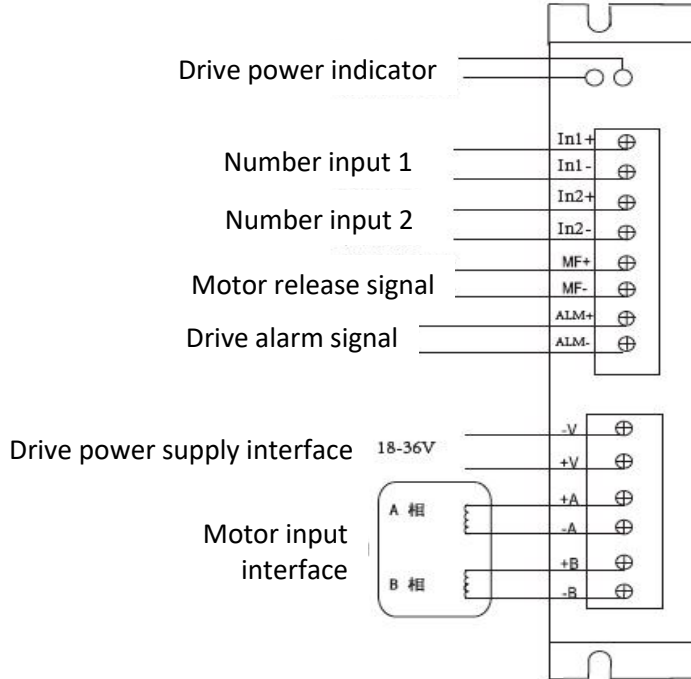

Drive front wiring diagram

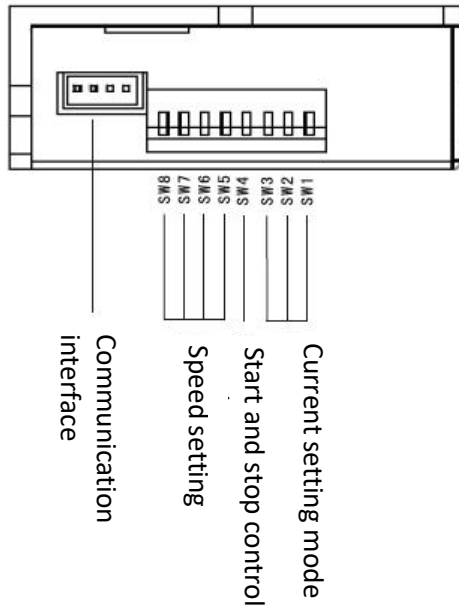

Schematic of the top of the drive



**Attention!**

- The personnel involved in wiring must have professional ability.
- No live wiring.
- The wiring can only be carried out after the installation is firm.
- Do not connect the power supply wrong, the input voltage should not exceed 36V.

## 4.2 Port Definition

### 4.2.1 Status indicator light

Color	Name	Features
Green	Power indicator light	When the power is on, the green indicator lights up.
Red	Fault indicator light	Drive overcurrent: Flicker once; Drive overvoltage: Flicker twice; Drive undervoltage: Flicker three times; Motor out of phase: Flicker four times;

### 4.2.2 Control signal input port

Port	Lean	Symbol	Function	Comments
	1	In1+	Step control signal photoelectric isolation positive and negative end	Connect the signal power supply, +5~24V input, higher than 24V need to connect the current limiting resistor
	2	In1-		The motor starts to run when the level changes from high to low
	3	In2+	Direction control signal photoelectric isolation positive and negative end	Direction signal input positive end, +5~24V input, higher than 24V need to connect the current limiting resistor
	4	In2-		Used to change the motor commutation
	5	MF+	Motor release signal photoelectric isolation positive and negative end	Connect the signal power supply, +5~24V input, higher than 24V need to connect the current limiting resistor
	6	MF-		When effective, turn off the coil current of the motor and the motor is in free state.

### 4.2.3 Power input and motor port

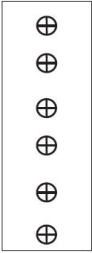
Port	Lead	Symbol	Name	Function
	1	V-	Power interface	DC18-36V
	2	V+		
	3	A+	Motor interface	Two phase stepper motor connector
	4	A-		
	5	B+		
	6	B-		

### 4.2.4 Dip switch

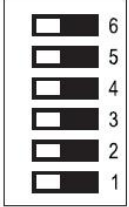
Port	Lead	Symbol	Function
	1	SW1	Current value setting
	2	SW2	
	3	SW3	
	4	SW4	Subdivision setting
	5	SW5	
	6	SW6	

## 4.3 Input/output port operation

The DM422IO driver has three digital inputs, photoelectric isolation, and the signal supports 5V-24V input. When the input signal is higher than 24V, the series current limiting resistance is required at the signal input end. The specific wiring diagram is as follows:

### 4.3.1 input

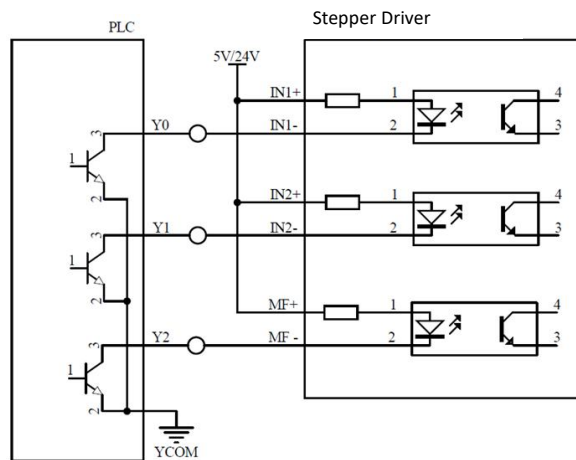

Common positive connection

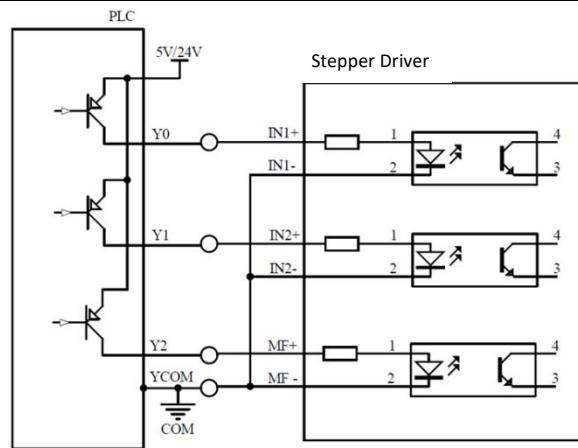

Common negative connection

### 4.3.2 Output

The DM422IO contains a photoelectric isolated output port that defaults to an alarm signal and outputs an alarm signal when the driver is in an error state.

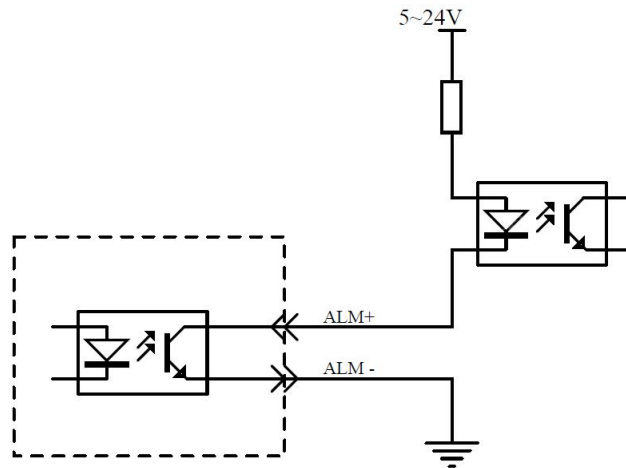

Note: The access voltage of the alarm output circuit does not exceed 30V, and the current does not exceed 50mA.

## Chapter 5 Drive operation parameter Settings

The DM422IO stepper motor driver uses a 6-bit dip switch to set the driver current and subdivision. The specific Settings are as follows:

### 5.1 Driver current setting

The DM422IO driver sets the peak output current or RMS value through SW1, SW2, SW3 dip switches.

Normally, the current is set to the rated current of the motor. If your system has high heating requirements, you can appropriately reduce the current to reduce the heat of the motor, but the output torque of the motor will be reduced at the same time. If you do not require continuous operation of the motor, you can appropriately increase the running current to obtain greater torque.

DM422IOAmmeter of current: (unit: A)

Current RMS	Current PEAK	SW1	SW2	SW3
Default	Default	ON	ON	ON
0.4	0.5	OFF	ON	ON
0.5	0.7	ON	OFF	ON
0.7	1.0	OFF	OFF	ON
0.9	1.3	ON	ON	OFF
1.1	1.6	OFF	ON	OFF
1.4	1.9	ON	OFF	OFF
1.6	2.2	OFF	OFF	OFF

Remark: Current RMS is the effective value, current Peak is the peak value of current

### 5.2 Drive subdivision Settings

The corresponding speed of the driver is set by SW5, SW6, SW7, and SW8 dial switches, as shown in the following table:

Serial	SW5	SW6	SW7	SW8	Speed
0	ON	ON	ON	ON	50
1	OFF	ON	ON	ON	150
2	ON	OFF	ON	ON	250
3	OFF	OFF	ON	ON	350
4	ON	ON	OFF	ON	450
5	OFF	ON	OFF	ON	550
6	ON	OFF	OFF	ON	650
7	OFF	OFF	OFF	ON	750
8	ON	ON	ON	OFF	850
9	OFF	ON	ON	OFF	950
10	ON	OFF	ON	OFF	5
11	OFF	OFF	ON	OFF	10
12	ON	ON	OFF	OFF	20
13	OFF	ON	OFF	OFF	30
14	ON	OFF	OFF	OFF	40
15	OFF	OFF	OFF	OFF	100

### 5.3 Control mode setting

SW4=OFF Control Mode 2

In1	In2	Running state
Invalid	Invalid	Lock machine
Valid	Invalid	Forward
Invalid	Valid	Lock machine
Valid	Valid	Reversal

SW4=ON Control Mode 1

In1	In2	Running state
Invalid	Invalid	Lock machine
Valid	Invalid	Forward
Invalid	Valid	Reversal
Valid	Valid	Lock machine

### 5.4 MF The motor releases a signal

The motor operating states corresponding to the MF signal when it is valid and invalid are as follows:

MF signal	Running state
Valid	Unlocked machine
Invalid	Locked machine

## Chapter 6 Driver Status Indicators

The DM422IO driver has an alarm prompt. After the driver alarms, the alarm indicator state indicates the alarm information of the driver. The specific alarm information is shown in the following table.

<b>Fault information</b>	<b>ALM Pilot lamp</b>	<b>Resetting</b>
Overcurrent or interphase short circuit	Flicker once	Power-off reset
Overvoltage of supply	Flicker twice	Automatic restoration of standard voltage
Undervoltage of supply	Flicker three times	Automatic restoration of standard voltage
Motor out of phase	Flicker four times	Recover after the phase sequence returns to normal

## Chapter 7 General Troubleshooting methods

phenomenon	Possible situation	Solution measure
Motor failure	The power light is off	Check the power supply circuit. The power supply is normal
	The motor locks the shaft but does not turn	The IO signal is weak and the signal current is increased
	Too little speed	Selection speed
	Whether the release signal MF is connected	Will release the signal MF does not connect
	Instruction input error	Check whether the upper computer has a switch output
Motor steering error	Motor reversal	Replace motor wiring sequence or adjust instruction direction
	The motor line has a break	Check whether the cable is in poor contact
	The motor has only one direction	Input port damage
Alarm indicator light	The motor wire is connected incorrectly	Check the wiring
	The voltage is too high or low	Check power supply
	The motor or drive is damaged	Replace the motor or drive
Wrong position or speed	Signal interference	Eliminate interference, reliable grounding
	Instruction input error	Check the upper computer instructions to ensure correct output
	Speed setting error	Check the DIP switch status and connect it correctly
	Motor tripping	Check whether the command speed is too large and the motor selection is small
The driver terminal is burned out	Short-circuit between terminals	Check the power polarity or external short circuit
	The internal resistance between terminals is too large	Check whether excess solder is added to the wire and wire connection to form tin pellets
Motor stalling	The acceleration and deceleration time is too short	Reduce the command acceleration or increase the driver filter parameter
	Motor torque too small	Select high torque motor
	Heavy load	Check the load weight and quality, adjust the mechanical structure
	Too little current	Check dip switches to increase the output current of the driver