

STEPPERONLINE®

User Manual

For

DM320T

2-Phase Digital Stepper Drive



Address: 15-4, #799 Hushan Road, Jiangning, Nanjing, China

Tel: 0086-2587156578

Web: www.omc-stepperonline.com

Sales: sales@stepperonline.com

Support: technical@stepperonline.com

Table of Contents

- 1. Introductions**..... 1
 - 1.1 Features..... 1
 - 1.2 Applications..... 1
- 2. Specifications**.....1
 - 2.1 Electrical Specifications..... 1
 - 2.2 Environment.....2
 - 2.3 Mechanical Specifications..... 2
 - 2.4 Elimination of Heat..... 2
- 3. Connection Pin Assignments and LED Indication**..... 3
 - 3.1 Connector P1 Configurations.....3
 - 3.2 Connector P2 Configurations.....3
 - 3.3 LED Light Indication..... 4
- 4. Control Signal Connector (P1) Interface**.....4
- 5. Motor Connection**.....5
 - 5.1 Connections of 4-lead Motor..... 5
 - 5.2 Connections of 6-lead Motor..... 5
 - 5.2.1 Half Coil Configuration**.....5
 - 5.2.2 Full Coil Configuration**..... 5
 - 5.3 Connections of 8-lead Motor..... 6
 - 5.3.1 Series Connection**..... 6
 - 5.3.2 Parallel Connection**..... 6
- 6. Power Supply Selection**..... 7
 - 6.1 Regulated or Unregulated Power Supply..... 7
 - 6.2 Power Supply Sharing..... 7
 - 6.3 Selecting Supply Voltage.....7
- 7. DIP Switch Configurations**.....7
 - 7.1 Microstep Resolution Configurations..... 8
 - 7.2 Current Configurations..... 8
 - 7.2.1 Dynamic Current Configurations**..... 8
 - 7.2.2 Standstill Current Configuration**..... 8
 - 7.3 Automatic Motor Matching & Self Configuration..... 9
- 8. Wiring Notes**.....9
- 9. Typical Connection**.....9
- 10. Sequence Chart of Control Signals**..... 10
- 11. Protection Functions**.....10
- 12. Troubleshooting**..... 11

1. Introductions

The DM320T is a digital stepper drive with simple design and easy setup. By implementing advanced stepper control technology, this stepper drive is able to power 2-phase and 4 phase stepper motors smoothly with optimal torque and low motor heating & noise. Its operating voltage is 10-30VDC and it can output up to 2.2A current. All the micro step and output current are done via DIP switches. Therefore, the DM320T are ideal choices for applications requiring simple step & direction control of NEMA11, 14, 16, 17 stepper motors.

1.1 Features

- Anti-Resonance for optimal torque, extra smooth motion, low motor heating and noise
- Motor auto-identification and parameter auto-configuration for optimal torque from wide-range motors
- Step & direction (PUL/DIR) control
- Multi-Stepping for smooth motor movement
- Optically isolated inputs
- Input voltage 10-30VDC
- 8 selectable micro-step resolutions of 400-12800 via DIP switches
- 8 selectable output current settings of 0.3 – 2.2A via DIP switches
- Soft-start with no “jump” when powered on
- Pulse input frequency up to 60 KHz.
- Automatic idle-current reduction
- Protections for over-voltage and over-current

1.2 Applications

The DM320T stepper drive are designed to power 2 phase (1.8) or 4-phase(0.9) NEMA11, 14, 16, 17 hybrid stepper motors. It can be easily adopted in many industries (CNC, medical, automation, packaging...), such as X-Y tables, engraving machines, labeling machines, mills, plasma, laser cutters, pick and place devices, and so on. Its excellent performance, simple design, and easy setup make it ideal for many step & direction control type applications.

2. Specifications

2.1 Electrical Specifications

Parameters	DM320T			
	Min	Typical	Max	Unit
Output Current	0.3	-	2.2 (1.6 RMS)	A
Supply Voltage	10	24	30	VDC
Logic signal current	7	10	16	mA
Pulse input frequency	0	-	60	kHz
Minimal pulse width	7.5	-	-	μS
Minimal direction setup	7.5	-	-	μS
Isolation resistance	100			MΩ

2.2 Environment

Cooling	Natural Cooling or Forced cooling	
Operating Environment	Environment	Avoid dust, oil fog and corrosive gases
	Ambient Temperature	0°C - 65°C (32°F - 149°F)
	Humidity	40%RH—90%RH
	Operating Temperature	0°C - 50°C (32°F - 122°F)
	Vibration	10-50Hz / 0.15mm
Storage Temperature	-20°C - 65°C (-4°F - 149°F)	
Weight	Approx. 90g (3.5 oz)	

2.3 Mechanical Specifications

(unit: mm [1inch=25.4mm])

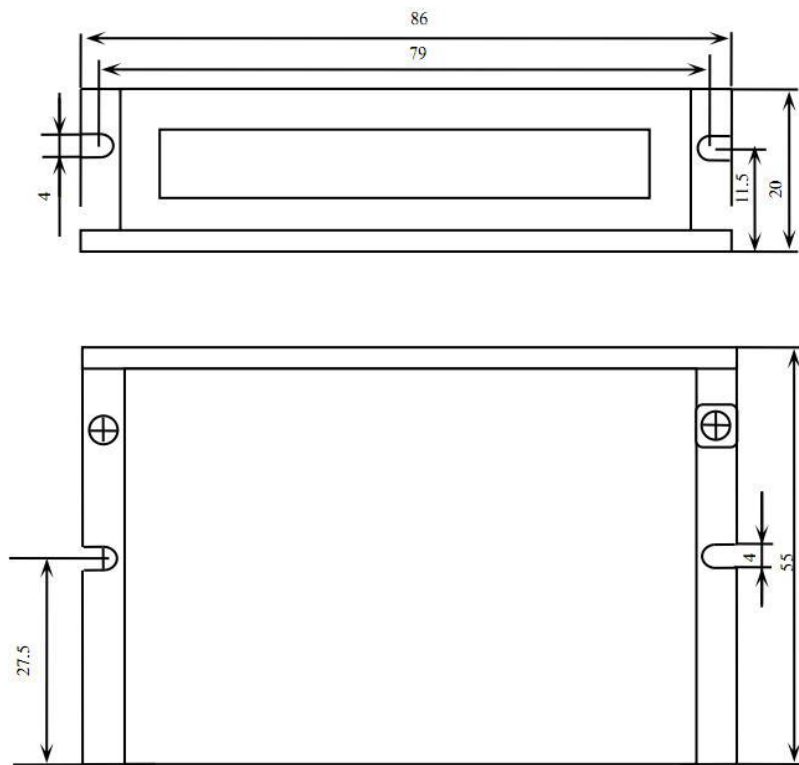

Figure 1: Mechanical specifications

*** Side mounting recommended for better heat dissipation**

2.4 Elimination of Heat

- DM320T reliable working temperature should be < 60°C (140°F)
- It is recommended to mount the drive vertically to maximize heat sink area. Use forced cooling method to cool if necessary.

3. Connection Pin Assignments and LED Indication

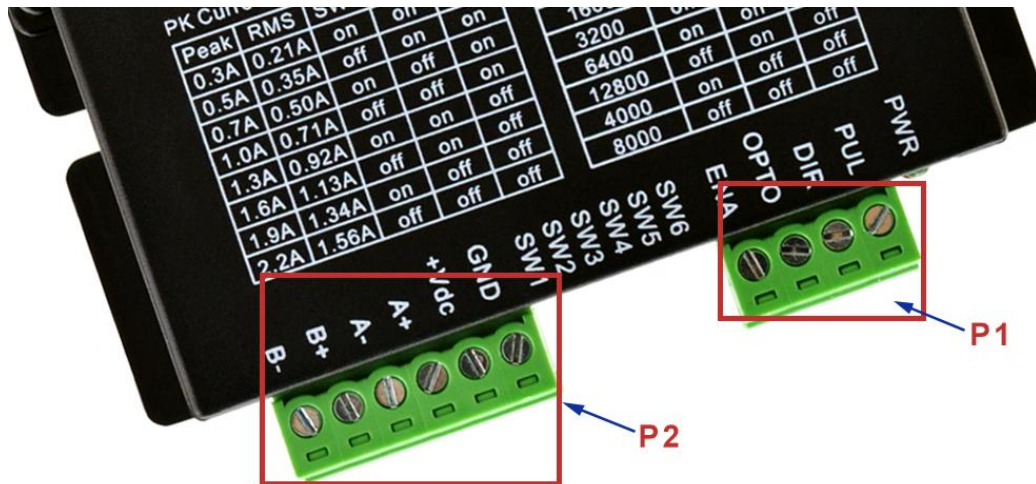

The DM320T has two connector blocks P1&P2 (see above picture). P1 is for control signals connections, and P2 is for power and motor connections. The following tables are brief descriptions of the two connectors. More detailed descriptions of the pins and related issues are presented in section 4, 5, 9.

3.1 Connector P1 Configurations

Pin Function	Details
PUL	Pulse signal: Pulse active at rising edge; 4-5V when PUL-HIGH, 0-0.5V when PUL-LOW. Minimal pulse width of 7.5µs. Add a resistor for current-limiting at +12V or +24V input logic voltage (1K for +12V, 2k for +24V). The same as DIR and ENA signals.
DIR	DIR signal: This signal has low/high voltage levels to represent two directions of motor rotation.. Minimal direction setup time of 5µs. Also swapping the connection of two wires of a coil (e.g. A+ and A-) to the drive will reverse motor direction.
OPTO	Opto-coupler power supply, and the typical voltage is +5V. Series connect resistors (at the PUL, DIR, ENA terminals) for current-limiting when +12V or +24V used.
ENA	Enable signal: This signal is used for enabling/disabling the drive. High level +5V (NPN control signal) for enabling the drive and low level for disabling the drive. NPN and Differential control signals are on the contrary, namely Low level for enabling. By default it is left UNCONNECTED (ENABLED) .



- Notes:** (1) shielding control signal wires is suggested;
 (2) To avoid interference, don't tie PUL/DIR control signal and motor wires together

3.2 Connector P2 Configurations

Pin Function	Details
GND	Power supply ground connection.
+Vdc	Power supply positive connection. Suggest 24VDC power supply voltage
A+, A-	Motor Phase A connections. Connect motor A+ wire to A+ Pin; motor A- wire to A-
B+, B-	Motor Phase B connections. Connect motor B+ wire to B+ Pin; motor B- wire to B-



Warning: Don't plug or unplug the P1 & P2 terminal block to avoid drive damage or injury when DM320T is powered on.

3.3 LED Light Indication

There are two LED lights for DM320T. The GREEN one is the power indicator which will be always on generally. The RED one is a protection indicator which will flash 1-2 times in a 3-second period, when protection enabled for a DM320T. Different number of flashes indicates different protection type (read section 11 for detail).

4. Control Signal Connector (P1) Interface

The DM320T can accept differential and single-ended inputs (including open-collector and NPN output). The DM320T has 3 optically isolated logic inputs which are located on connector P1 to accept line drive control signals. These inputs are isolated to minimize or eliminate electrical noises coupled with the drive control signals. Recommend using line drive control signals to increase noise immunity for the drive in interference environments. In the following figures, connections to open-collector and NPN signals are illustrated.

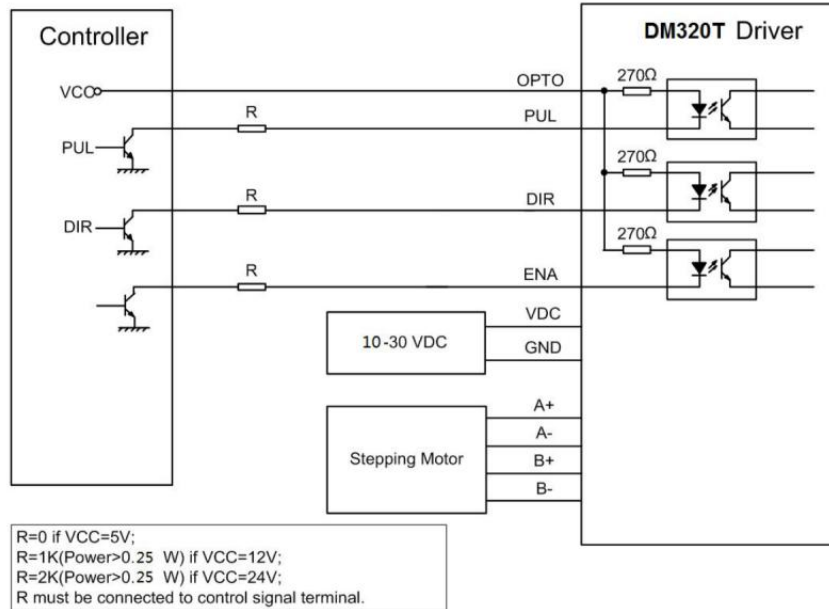

Figure 2: Connections to open-collector signal (common-anode)

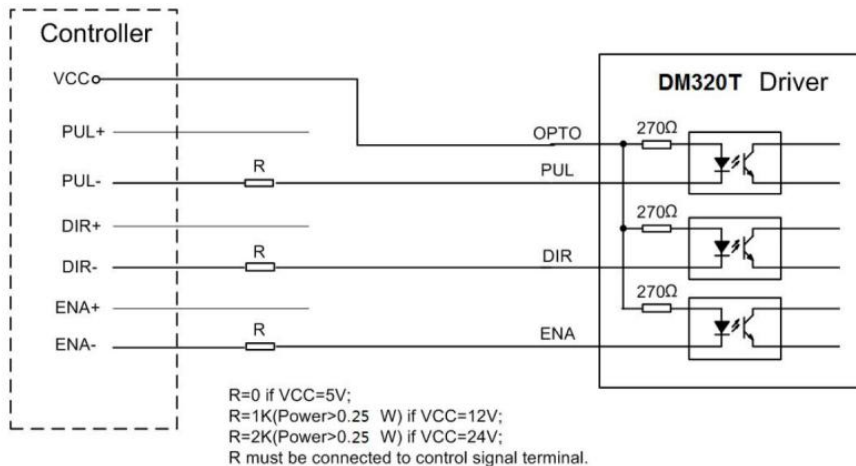

Figure 3: Connections to difference control signal

5. Motor Connection

The DM320T can drive 2-phase and 4-phase bipolar hybrid stepper motors with 4, 6, or 8 wires.

5.1 Connections of 4-lead Motor

The 4 lead motors are the least flexible and easy to connect. And the Speed – torque of motor depends on winding inductance. The output current from drive that is multiply the specified phase current by 1.4 to determine the peak output current.

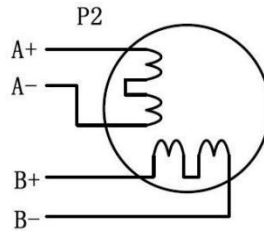

Figure 4: 4-lead Motor Connections

5.2 Connections of 6-lead Motor

Like 8 lead stepping motors, 6 lead motors have two configurations available for high speed or high torque operations. The higher speed configuration, or half coil, is described, because it uses one half of the motor’s inductor windings. The higher torque configuration, or full coil, uses the full coil windings.

5.2.1 Half Coil Configuration

As previously stated, the half coil configuration uses 50% of the motor phase windings. This gives lower inductance, hence, lower torque output. Like the parallel connection of 8 lead motor, the torque output will be more stable at higher speeds. This configuration is also referred to as half chopper. In setting the drive output current multiply the specified per phase (or unipolar) current rating by 1.4 to determine the peak output current.

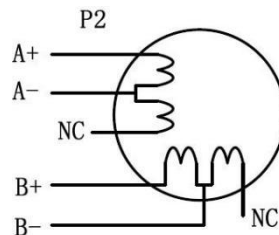

Figure 5: 6-lead motor half coil (higher speed) connections

5.2.2 Full Coil Configuration

The full coil configuration on a six lead motor should be used in applications where higher torque at lower speed is desired. This configuration is also referred to as full copper. In full coil mode, the motors should be run at only 70% of their rated current to prevent overheating.

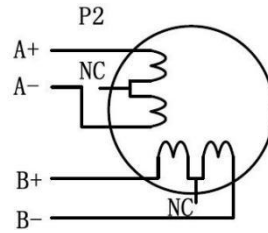

Figure 6: 6-lead motor full coil (higher torque) connections

5.3 Connections of 8-lead Motor

8 lead motors offer a high degree of flexibility to the system designer in that they may be connected in series or parallel, thus satisfying a wide range of applications.

5.3.1 Series Connection

A series motor configuration would typically be used in applications where a higher torque at lower speed is required. Because this configuration has the most inductance, the performance will start to degrade at higher speed. In series mode, the motors should also be run at only 70% of their rated current to prevent overheating.

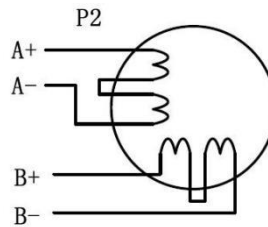

Figure 7: 8-lead motor series connections

5.3.2 Parallel Connection

An 8 lead motor in a parallel configuration offers a more stable, but lower torque at lower speeds. But because of the lower inductance, there will be higher torque at higher speeds. Multiply the phase (or unipolar) current rating by 1.96, or the bipolar current rating by 1.4, to determine the peak output current.

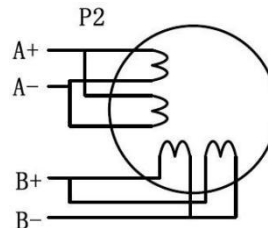

Figure 8: 8-lead motor parallel connections

6. Power Supply Selection

The DM320T can power medium and small size stepping motors (frame size from NEMA11 to 17). To get good driving performances, it is important to select supply voltage and output current properly. Generally speaking, supply voltage determines the high speed performance of the motor, while output current determines the output torque of the driven motor (particularly at lower speed). Higher supply voltage will allow higher motor speed to be achieved, at the price of more noise and heating. If the motion speed requirement is low, it's better to use lower supply voltage to decrease noise, heating and improve reliability.

6.1 Regulated or Unregulated Power Supply

Both regulated and unregulated power supplies can be used to supply the drive. However, unregulated power supplies are preferred due to their ability to withstand current surge and fast response for current change. If you prefer to a regulated power supply, it is suggested to choose such a power supply specially designed for stepper/servo controls Or, in the case when only normal switching power supplies are available, it is important to use "OVERSIZE" high current output rating power supplies (for example, using a 4A power supply for 3A stepper motor) to avoid problems such as current clamp. On the other hand, if unregulated supply is used, one may use a power supply of lower current rating than that of motor (typically 50% ~ 70% of motor current). The reason is that the drive draws current from the power supply capacitor of the unregulated supply only during the ON duration of the PWM cycle, but not during the OFF duration. Therefore, the average current withdrawn from power supply is considerably less than motor current. For example, two 3A motors can be well supplied by one power supply of 4A rating.

6.2 Power Supply Sharing

Multiple DM320T drives can share one power supply to reduce cost, if that power supply has enough power capacity. To avoid cross interference, connect each stepper drive directly to the shared power supply separately. To avoid cross interference, DO NOT daisy-chain connect the power supply input pins of the Drivers. Instead connect them to power supply separately.

6.3 Selecting Supply Voltage

The DM320T is designed to operate within 10-30VDC voltage input. When selecting a power supply, besides voltage from the power supply power line voltage fluctuation and back EMF voltage generated during motor deceleration needs also to be taken into account. Ideally it is suggested to use a power supply with the output voltage of 24VDC, leaving room for power line voltage fluctuation and back-EMF.

Higher supply voltage can increase motor torque at higher speeds, thus helpful for avoiding losing steps. However, higher voltage may cause bigger motor vibration at lower speed, and it may also cause over-voltage protection or even drive damage. Therefore, it is suggested to choose only sufficiently high supply voltage for intended applications.

7. DIP Switch Configurations

This drive uses an 6-bit DIP switch to set microstep resolution, and motor operating current, as shown below:

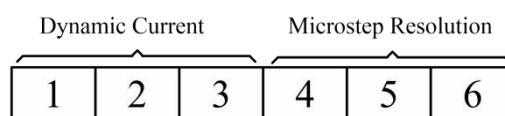

7.1 Microstep Resolution Configurations

Microstep resolution is set by SW4, 5, 6 of the DIP switches as shown in the following table:

Microstep	Steps/rev.(for 1.8° motor)	SW4	SW5	SW6
2	400	ON	ON	ON
4	800	OFF	ON	ON
8	1600	ON	OFF	ON
16	3200	OFF	OFF	ON
32	6400	ON	ON	OFF
64	12800	OFF	ON	OFF
20	4000	ON	OFF	OFF
40	8000	OFF	OFF	OFF

7.2 Current Configurations

For a given motor, higher drive current will make the motor to output more torque, but at the same time causes more heating in the motor and drive. Therefore, output current is generally set to be such that the motor will not overheat for long time operation. Since parallel and serial connections of motor coils will significantly change resulting inductance and resistance, it is therefore important to set drive output current depending on motor phase current, motor leads and connection methods. Phase current rating supplied by motor manufacturer is important in selecting drive current, however the selection also depends on leads and connections.

The first three bits (SW1, 2, 3) of the DIP switch are used to set the dynamic current. Select a setting closest to your motor's required current.

7.2.1 Dynamic Current Configurations

Peak Current	RMS Current	SW1	SW2	SW3
0.3A	0.21A	ON	ON	ON
0.5A	0.35A	OFF	ON	ON
0.7A	0.49A	ON	OFF	ON
1.0A	0.71A	OFF	OFF	ON
1.3A	0.92A	ON	ON	OFF
1.6A	1.13A	OFF	ON	OFF
1.9A	1.34A	ON	OFF	OFF
2.2A	1.56A	OFF	OFF	OFF

Notes: Due to motor inductance, the actual current in the coil may be smaller than the dynamic current setting, particularly under high speed condition.

7.2.2 Standstill Current Configuration

The standstill current is set to be 50% of the selected output current. It means standstill current automatically reduced to 50% of the selected dynamic current 0.4 second after the last pulse.

7.3 Automatic Motor Matching & Self Configuration

When powered on a DM320T will automatically configure itself with the best settings to match the driven stepper motor for optimal performance. No action is needed.

8. Wiring Notes

- In order to improve anti-interference performance of the drive, it is recommended to use twisted pair shield cable.
- To prevent noise incurred in PUL/DIR signal, pulse/direction signal wires and motor wires should not be tied up together. It is better to separate them by at least 10 cm, otherwise the disturbing signals generated by motor will easily disturb pulse direction signals, causing motor position error, system instability and other failures.
- If only one power supply serves multiple DM320T drives, separately connecting the drives to the power supply is recommended instead of daisy-chaining.
- It is prohibited to pull and plug connector P2 while the drive is powered ON, because there is high current flowing through motor coils (even when motor is at standstill). Pulling or plugging connector P2 with power on will cause extremely high back-EMF voltage surge, which may damage the drive.

9. Typical Connection

A complete stepping system should include stepping motor, stepping drive, power supply and controller (pulse generator). A typical connection is shown as figure 9.

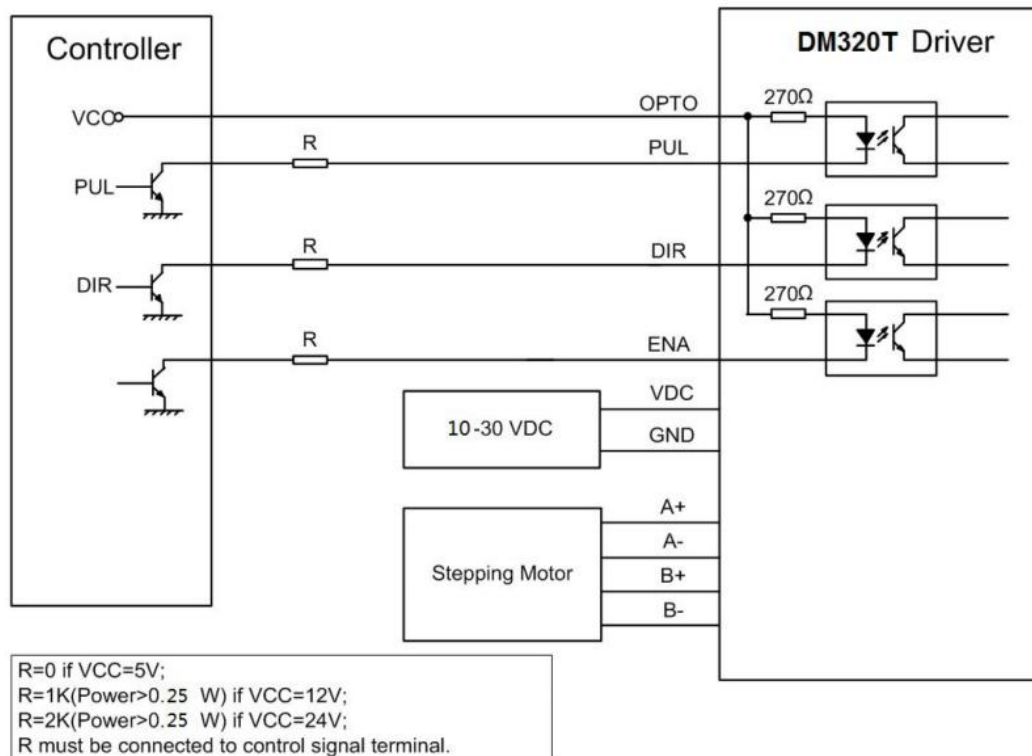

Figure 9: Typical connection

10. Sequence Chart of Control Signals

In order to avoid some fault operations and deviations, PUL, DIR and ENA should abide by some rules, shown as following diagram:

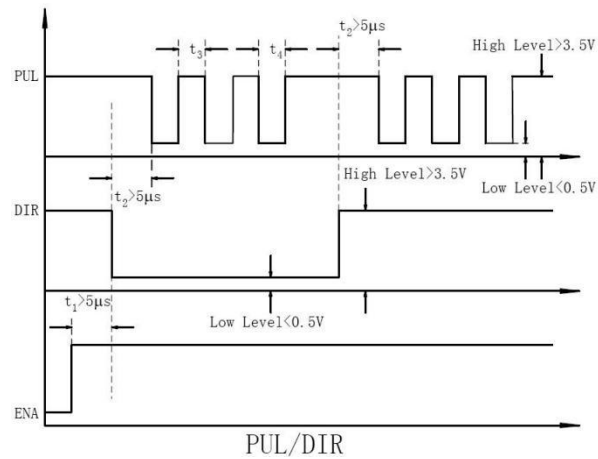

Figure 10: Sequence chart of control signals

Remark:

- a) t_1 : ENA must be ahead of DIR by at least $5\mu s$. Usually, ENA+ and ENA- are NC (not connected). See “Connector P1 Configurations” for more information.
- b) t_2 : DIR must be ahead of PUL effective edge by $5\mu s$ to ensure correct direction;

11. Protection Functions

To improve reliability, the drive incorporates some built-in protections features.

Priority	Time(s) of Blink	Sequence wave of red LED	Description
1st	1		Over-current protection activated when peak current exceeds the limit.
2nd	2		Over-voltage protection activated when drive working voltage is greater than 34VDC
3rd	3		Reserved.

When above protections are active, the motor shaft will be free or the red LED blinks. Reset the drive by repowering it to make it function properly after removing above problems.

12. Troubleshooting

In the event that your drive doesn't operate properly, the first step is to identify whether the problem is electrical or mechanical in nature. The next step is to isolate the system component that is causing the problem. As part of this process you may have to disconnect the individual components that make up your system and verify that they operate independently. It is important to document each step in the troubleshooting process. You may need this documentation to refer back to at a later date, and these details will greatly assist our Technical Support staff in determining the problem should you need assistance.

Many of the problems that affect motion control systems can be traced to electrical noise, controller software errors, or mistake in wiring.

Problem Symptoms and Possible Causes

Symptoms	Possible Problems
Motor is not rotating	No power
	Microstep resolution setting is wrong
	DIP switch current setting is wrong
	Fault condition exists
	The drive is disabled
Motor rotates in the wrong direction	Motor phases may be connected in reverse
The drive in fault	DIP switch current setting is wrong
	Something wrong with motor coil
Erratic motor motion	Control signal is too weak
	Control signal is interfered
	Wrong motor connection
	Something wrong with motor coil
	Current setting is too small, losing steps
Motor stalls during acceleration	Current setting is too small
	Motor is undersized for the application
	Acceleration is set too high
	Power supply voltage too low
Excessive motor and drive heating	Inadequate heat sinking / cooling
	Automatic current reduction function not being utilized
	Current is set too high