

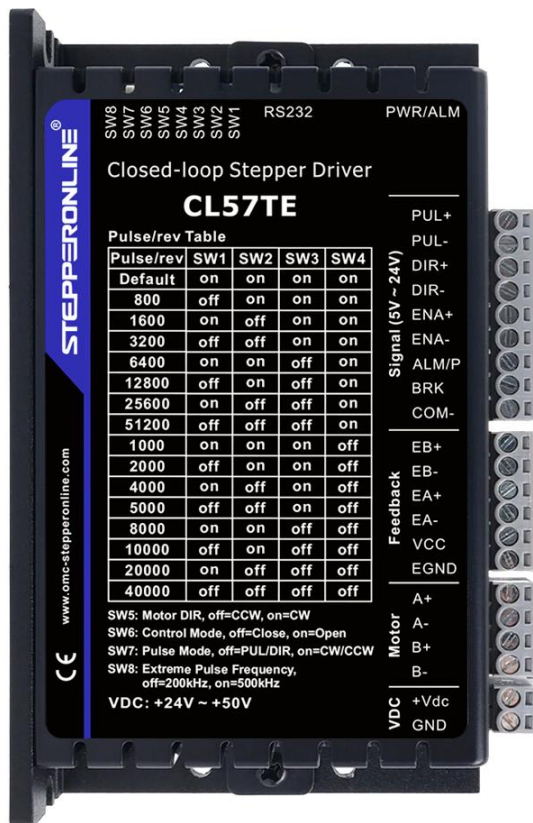

# CL57TE

Closed Loop Stepper Drive

## User Manual



©2025 All Rights Reserved

Address: 15-4, #799 Hushan Road, Jiangning, Nanjing, China

Tel: 0086-2587156578

Web: [www.omc-stepperonline.com](http://www.omc-stepperonline.com)

Sales: [sales@stepperonline.com](mailto:sales@stepperonline.com)

Support: [technical@stepperonline.com](mailto:technical@stepperonline.com)

## Notice

Read this manual carefully before any assembling and using. Incorrect handling of products in this manual can result in injury and damage to persons and machinery. Strictly adhere to the technical information regarding installation requirements.

This manual is not for use or disclosure outside of Stepperonline except under permission. All rights are reserved. No part of this manual shall be reproduced, stored in retrieval form, or transmitted by any means, electronic, mechanical, photocopying, recording, or otherwise without approval from Stepperonline. While every precaution has been taken in the preparation of the book, Stepperonline assumes no responsibility for errors or omissions. Neither is any liability assumed for damages resulting from the use of the information contained herein.

This document is proprietary information of Stepperonline that is furnished for customer use ONLY. Information in this document is subject to change without notice and does not represent a commitment on the part of Stepperonline. Therefore, information contained in this manual may be updated from time-to-time due to product improvements, etc., and may not conform in every respect to former issues.

## Record of Revisions

<b>Revision</b>	<b>Date</b>	<b>Description of Release</b>
<i>1.0</i>	<i>July, 2025</i>	<i>Initial Release</i>

## Table of Content

1. Introduction .....	1
1.1 Features .....	1
1.2 Applications .....	1
2. Specifications .....	2
2.1 Electrical Specifications .....	2
2.2 Environment .....	2
2.3 Mechanical Specifications .....	3
2.4 Heat Dissipation .....	3
3. Connections and LED Indication .....	4
3.1 Connector P1 – Control Signals and Digital Outputs Connector .....	4
3.1.1 Pin Assignments of P1 .....	4
3.1.2 Connection of Control Signals .....	5
3.1.3 Connection of ALM Signal .....	5
3.1.4 Connection of Brake Signal .....	6
3.2 Connector P2 - Encoder Connection .....	7
3.3 Connector P3 - Motor Connection .....	7
3.4 Connector P4 – Power Supply Connection .....	7
3.5 Connector P5 – Tuning Port .....	8
3.6 LED Light Indication .....	8
4. Motor Selection .....	8
5. Power Supply Selection .....	8
5.1 Regulated or Unregulated Power Supply .....	9
5.2 Power Supply Sharing .....	9
5.3 Selecting Supply Voltage .....	9
6. DIP Switch Configurations .....	9
6.1 S1 - DIP Switch Configurations .....	9
6.2.1 Micro Step (SW1-SW4) .....	10
6.2.2 Mode Setting (SW5 - SW8) .....	10
7. Typical Connection .....	11
8. Sequence Chart of Control Signals .....	11
9. Fault Protections .....	12
10. Software Configuration .....	12
11. Accessories .....	13
12. Troubleshooting .....	13
13. Warranty .....	15
Appendix. Powering a Third-Party Motor with CL57TE .....	16

## 1. Introduction

Stepperonline CL57TE is a new closed loop stepper drive designed to solve the loss of step problem in open loop stepper control systems, thus increase system reliability at minimal cost increase. It implements advanced control algorithm of Stepperonline based on its tens of years' experience in stepper and servo controls. The CL57TE is reliable and affordable and performs excellent in many industrial applications such as CNC, medical, electronics, packaging...

The CL57TE can power 2-phase NEMA 14, 17, 23, and 24 stepper motors with incremental encoders. Compared with traditional open loop stepper systems, CL57TE adopted closed loop step system can eliminate potential loss of step, make real-time position error correction, and do not need torque reservation (100% torque implementation). Also it can power the driven stepper motor with reduced heating, lower noise, low vibration...

### 1.1 Features

- No loss of step & No torque reservation & No hunting or overshooting & No tuning for easy setup
- Enhance performance, especially at low speed application (<60RPM)
- Auto-tuning to match wide-range NEMA 17, 23 and 24 closed-loop stepper motors
- Soft-start with no "jump" when powered on
- 20-50VDC supply voltage, max 7.0A output current
- Max 500 KHz input frequency
- 15 micro step settings of 800-51,200 via DIP switches, or 200-51,200 via software (increase by 200)
- 2 out current settings and gain tuning via S1 rotating switch
- Optically isolated inputs with 5~ 24V
- Motor rotating direction setting by SW5
- Closed loop or open loop control setting by SW6
- Step&Direction or CW&CCW pulse type setting by SW7
- Position command filter setting by SW8
- A fault output and a configurable output for alarm or in position
- Over-voltage, over-current protections, position following error, etc

### 1.2 Applications

When CL57TE closed loop stepper drive is implemented with a compatible stepper motor with encoder, the closed stepper system can be adopted in many small to median speed applications such as CNC routers, CNC mills, CNC laser cutters, CNC plasma, lab automation instruments, plotters, medical equipment, electronic equipment, small packaging machines, etc.

## 2. Specifications

### 2.1 Electrical Specifications

Parameter description/Model	CL57-TE
Continuous output current (factory default) (A)	0~6
Input power voltage (V)	DC 24~50
quality (kg)	0.3
Signal input voltage range	5~24
Logic input current (mA)	7~20
Size(mm)	118*68.7*25.5
High-speed input pulse frequency (5V) 50% duty cycle (kHz)	500
High-speed input pulse frequency (24V) 50% duty cycle (kHz)	200
Insulation resistor (MΩ)	100
Alarm output logic current (mA)	100

Parameters	Min	Typical	Max	Unit
Output Current (peak)	0.5	-	7.0	A
Operating Voltage	20	24, 36, 48	50	VDC
Logic signal current	7	10	16	mA
Pulse input frequency (5V @ 50% dutycycle)	0	-	500	kHz
Pulse input frequency (24V @ 50% dutycycle)	0	-	200	KHz
Minimal pulse width	1μS @ 5V, or 2.5μS @ 24V		-	μS
Minimal direction setup	5.0	-	-	μS
Isolation resistance	100			MΩ

### 2.2 Environment

Cooling	Natural Cooling or Forced Cooling	
Operating Environment	Environment	Avoid dust, oil fog and corrosive gases
	Humidity	40%RH—90%RH
	Operating Temperature	0°C — 40°C (32°F - 104°F)
	Vibration	10-50Hz / 0.15mm
Storage Temperature	-20°C — 65°C (-4°F - 149°F)	
Weight	Approx. 280 g (9.9 Oz)	

### 2.3 Mechanical Specifications

(unit: mm [1inch=25.4mm])

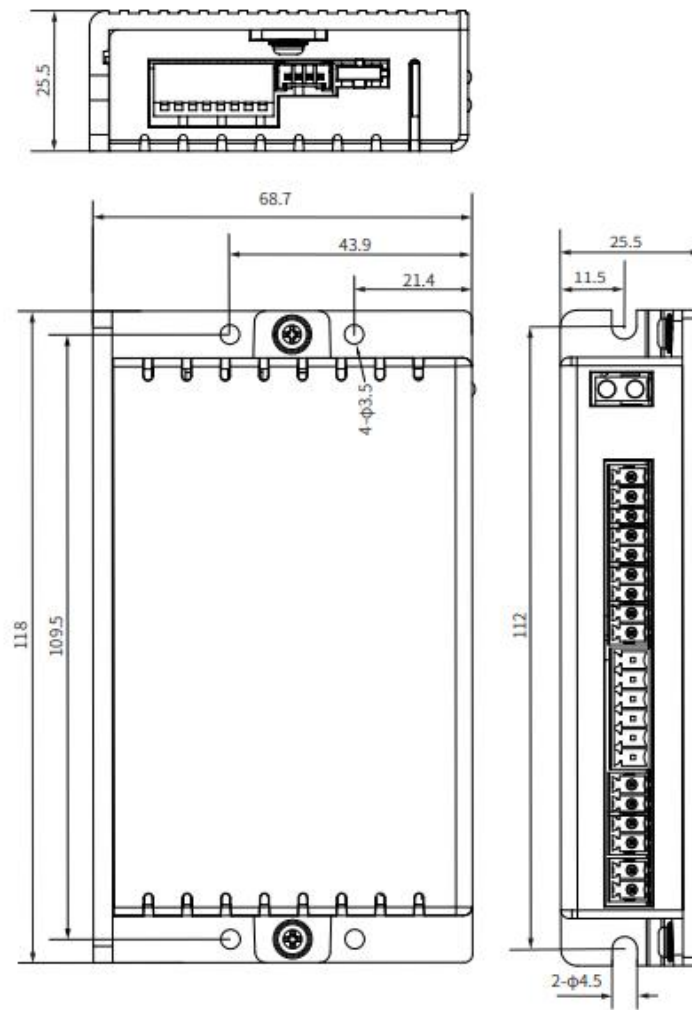

Figure 1: Mechanical specifications

### 2.4 Heat Dissipation

- Temperature of the drive during working should be no more than 65°C (149°F)
- It is recommended to mount the drive vertically to maximize heat dissipation. Mount a cooling fan nearby if necessary.
- If multiple CL57TE drives are installed, it is suggested to keep a minimal 30mm (1.2 inches) between two of them.

### 3. Connections and LED Indication

CL57TE closed loop stepper drive has 4 connection blocks from P1 to P4 (see figure 2).

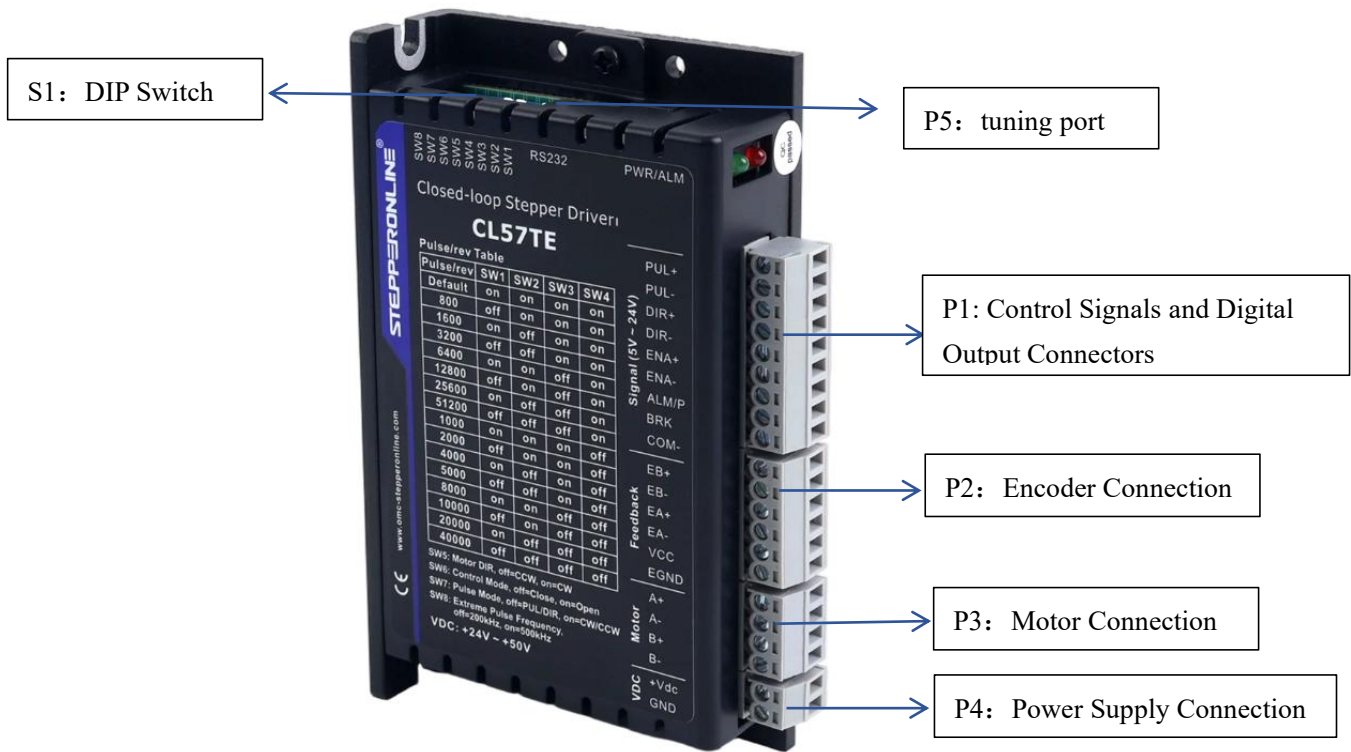

Figure 2: CL57TE connectors

#### 3.1 Connector P1 – Control Signals and Digital Outputs Connector

##### 3.1.1 Pin Assignments of P1

The P1 connector in Figure 2 contains connections for control signals and 2 digital output. See the following table for details.

PIN	I/O	Details
PUL+ (CW+)	I	Pulse and Direction Connection: (1)The pulse signal supports 5~24V compatible, no string resistance is required to connect to the 24V pulse signal,the factory default is effective on the falling edge; (2) Maximum 200 KHz input frequency (3) The width of PUL signal is at least 2.5µs, duty cycle is recommended 50% (4) DIR signal requires advance PUL signal minimum 5 µs in single pulse mode
PUL- (CW-)	I	
DIR+ (CCW+)	I	
DIR- (CCW-)	I	
ENA+	I	

<b>ENA-</b>	<b>I</b>	<p><u>Enable Connection:</u> (no connected default.)</p> <p>(1) The ENA signal supports 5~24V compatible, the factory default is effective on the falling edge;</p> <p>(2) Disable the drive by 4.5- 24V input connection; enable the drive by 0-0.5V connection</p> <p>(3) ENA signal requires advance DIR signal minimum 5μs in single pulse mode</p> <p>(4) Enable time to be at least 200ms</p>
<b>ALM</b>	<b>O</b>	<u>Alarm:</u> A configurable OC output signal. Can be set to fault output or in position output via software. It takes a sinking or sourcing 100mA current at 5-24V@30mA
<b>BRK</b>	<b>O</b>	<u>Brake:</u> Max. 24@100mA, connect with brake coil, relay and diode.
<b>COM-</b>	<b>O</b>	Common connection of single-end output signals (common-cathode)

**Notes:**

- (1) Shielding control signal wires is suggested;
- (2) To avoid/reduce interference, do not tie control signal cables and power wires together;
- (3) Brake output need to connect a relay and diode

3.1.2 Connection of Control Signals

The CL57TE can accept differential and single-ended control signal inputs (open-collector and PNP output). The CL57TE has 3 optically isolated control inputs, PUL, DIR, and ENA. Refer to the following two figures for connections of open-collector and PNP signals.

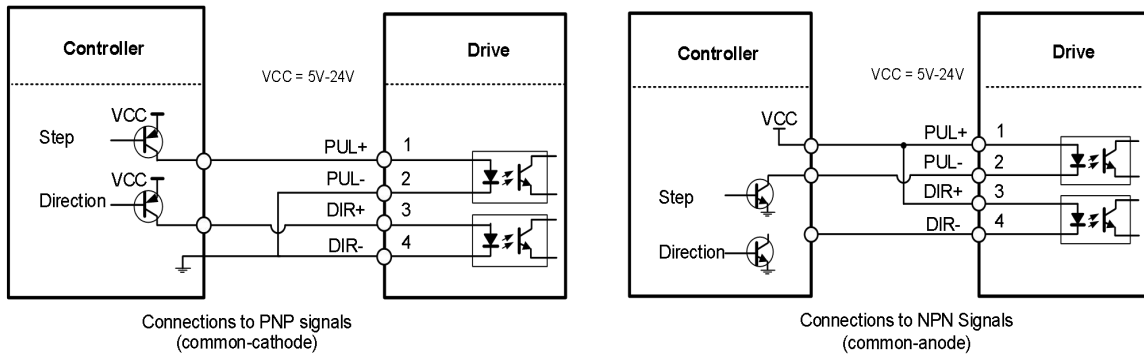

Figure 3: Control Signals Connection

**Notes:** (1) ENA signal is no connected as default;

3.1.3 Connection of ALM Signal

- *Fault*

FAULT output is the default configuration. This output signals a fault condition including over-voltage, over-current, or position following error. This output can be used to drive devices such as a relay, a LED, etc., or as an input signal to electronic devices like a PLC.

For example, in a multi-axis system like a CNC machine when one of the axes fails such a fault output signal can be feedback to the motion controller for a followed action (e.g., auto machine shutdown, auto error clearing, etc.).

- *In Position*

Use Stepperonline MotionStudio software to configure this output as an IN POSITION output. In this case, an output signal can be sent out when the targeted position is in the “Target” range (see *parameter Distance to Send "In position" Output Signal* in software manual) to external devices such as relays, motion controllers, PLCs, IO boards, etc.

Refer to the following figure for ALM connection.

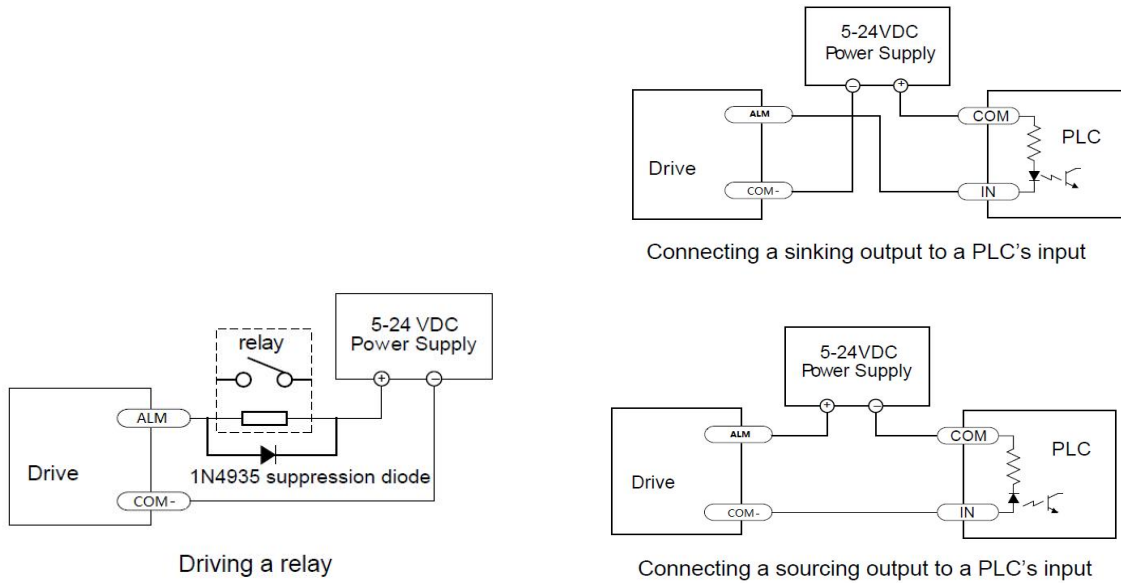

Figure 4: ALM Signals Connection

### 3.1.4 Connection of Brake Signal

This signal can be used for automatic brake control while system power failure.

When use a 24V electromagnetic relay, it is recommended to connect a diode (such as IN4007) in parallel, the polarity should not be reversed. The specific connection is as follows figure.

When use a solid-state relay (SSR), its advantages are fast response, no need to add diodes, no noise; specification such as “Non-contact, DC control DC, current limit protection 0.6-10A”.

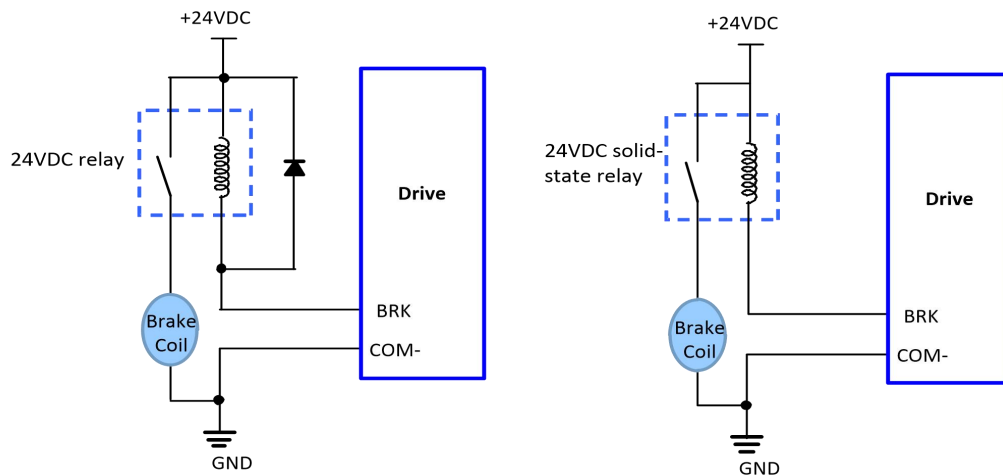

Figure 5: Brake Output Connection

### 3.2 Connector P2 - Encoder Connection

The P2 connector in Figure 2 is for encoder signal connection. Refer to the following table for details.

Drive Pin Name	Description
EB+	Encoder B+ input connection
EB-	Encoder B- input connection
EA+	Encoder A+ input connection
EA-	Encoder A- input connection
VCC	Encoder +5V voltage output connection
EGND	Power ground connection

### 3.3 Connector P3 - Motor Connection

The P3 connector in Figure 2 is for motor connection. Refer to the following table for details.

Pin Name	Details
A+	Stepper motor A+ connection. Connect motor A+ wire to this pin
A-	Stepper motor A- connection. Connect motor A- wire to this pin
B+	Stepper motor B+ connection. Connect motor B+ wire to this pin
B-	Stepper motor B- connection. Connect motor B- wire to this pin

### 3.4 Connector P4 – Power Supply Connection

The P4 connector in Figure 2 is for power supply connection. Refer to the following table for details.

Pin Name	Details
+Vdc	Power supply positive connection. 20-50VDC power supply voltage
GND	Power supply ground connection.

**Notes:** see Appendix B for compatible Stepperonline power supplies

### 3.5 Connector P5 – Tuning Port

The P5 connector in Figure 2 is a RS232 communication port for PC connection. Refer to the following pin definitions.

CL-TE has a tuning port with RS232 to modify the drive parameters, it is just used to modify parameter, not for equipment control because neither precision nor stability is sufficient. If you need a field bus drive, use a Stepperonline RS485 or EtherCAT type drives

The interface definition is as follows:

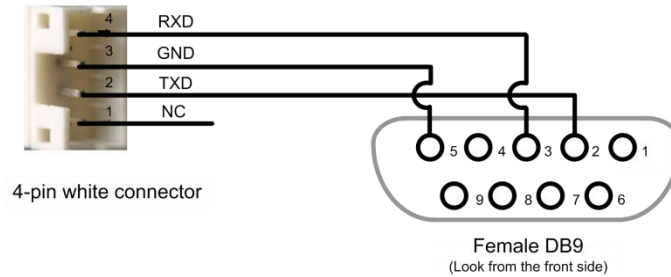

### 3.6 LED Light Indication

There are two LED lights for CL57TE, one red and one green. The GREEN one is the power indicator which will be always on generally. The RED one is a protection indicator. It is off always when CL57TE operates normally, but will flash 1, 2 or 7 times in a 5-second period when error protection is enabled. Different number of flashes indicates different protection type (read Section 9).

## 4. Motor Selection

The CL57TE is designed to power 2-phase (or 4-phase 0.9 degree) NEMA 17/23/24 stepper motors under 1000-line incremental encoders (recommend 1000-line). Stepperonline offers many high-performance stepper motors compatible with the CL57TE which you can find in the Appendix A of this document. The CL57TE can also power similar stepper motors with incremental encoders from third-party suppliers.

## 5. Power Supply Selection

The CL57TE can power small and medium size closed loop stepper motors (frame size from NEMA17 to 24) from Stepperonline (see Appendix A) or other motor manufacturers. To get good system performance, it is important to select proper supply voltage and output current. Generally speaking, supply voltage determines the high speed performance of the motor, while output current determines the output torque of the driven motor (particularly at lower speed). Higher supply voltage will allow higher motor speed to be achieved, at the price of more noise and heating. If the motion speed requirement is low, it's better to use lower supply voltage to decrease noise, heating and improve reliability.

**Notes:** See Appendix B at the end of this document for StepperonlineCL57TE compatible switching power supplies specially designed for stepper & servo controls.

### 5.1 Regulated or Unregulated Power Supply

Both regulated and unregulated power supplies can be used to supply the drive. However, unregulated power supplies are preferred due to their ability to withstand current surge and fast response for current change. If you prefer to a regulated power supply, it is suggested to choose such a power supply specially designed for stepper/servo controls such as Stepperonline RPS series (<http://www.Stepperonline.com/producttypes.aspx?producttype=regulated-switching>). Or, in the case when only normal switching power supplies are available, it is important to use "OVERSIZE" high current output rating power supplies (for example, using a 4A power supply for 3A stepper motor) to avoid problems such as current clamp. On the other hand, if unregulated supply is used, one may use a power supply of lower current rating than that of motor (typically 50%-70% of motor current). The reason is that the drive draws current from the power supply capacitor of the unregulated supply only during the ON duration of the PWM cycle, but not during the OFF duration. Therefore, the average current withdrawn from power supply is considerably less than motor current. For example, two 3A motors can be well supplied by one power supply of 4A rating.

### 5.2 Power Supply Sharing

Multiple CL57TE drives can share one power supply to save space and reduce cost, if that power supply has enough power capacity. To avoid cross interference, connect each stepper drive directly to the shared power supply separately. To avoid cross interference, DO NOT daisy-chain connect the power supply input pins of the Drivers. Instead connect them to power supply separately.

### 5.3 Selecting Supply Voltage

The CL57TE is designed to operate within 20-50VDC voltage input. When selecting a power supply, besides voltage from the power supply power line voltage fluctuation and back EMF voltage generated during motor deceleration needs also to be taken into account. Ideally it is suggested to use a power supply with the output of 20-48VDC, leaving room for power line voltage fluctuation and back-EMF.

Higher supply voltage can increase motor torque at higher speeds, thus helpful for avoiding losing steps. However, higher voltage may cause bigger motor vibration at lower speed, and it may also cause over-voltage protection or even drive damage. Therefore, it is suggested to choose only sufficiently high supply voltage for intended applications.

## 6. DIP Switch Configurations

### 6.1 S1 - DIP Switch Configurations

The 8-bit is located on the side (DIP switch S1 in Figure 2) and used to configure settings of micro step resolution, output current, and motor standstill current as shown below.

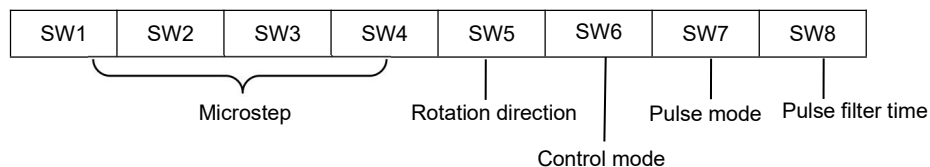

Figure 6: DIP switches

**6.2.1 Micro Step (SW1-SW4)**

Each CL57TE has 15 microstep settings which can be configured through DIP switches SW1, SW2, SW3 and SW4. See the following table for detail.

Micro step	Pulses/Rev. (for 1.8°motor)	SW1	SW2	SW3	SW4
Default	ON	ON	ON	ON	ON
800	OFF	ON	ON	ON	ON
1600 (Factory)	ON	OFF	ON	ON	ON
3200	OFF	OFF	ON	ON	ON
6400	ON	ON	OFF	ON	ON
12800	OFF	ON	OFF	ON	ON
25600	ON	OFF	OFF	ON	ON
51200	OFF	OFF	OFF	ON	ON
1000	ON	ON	ON	OFF	OFF
2000	OFF	ON	ON	OFF	OFF
4000	ON	OFF	ON	OFF	OFF
5000	OFF	OFF	ON	OFF	OFF
8000	ON	ON	OFF	OFF	OFF
10000	OFF	ON	OFF	OFF	OFF
20000	ON	OFF	OFF	OFF	OFF
40000	OFF	OFF	OFF	OFF	OFF

Note: “factory” means the factory switch setting, “default” means the parameters can be set by Stepperonline software.

**6.2.2 Mode Setting (SW5 - SW8)**

	Function	ON	OFF
<b>SW5</b>	Rotation Direction	CW (clockwise)	CCW (counterclockwise)
<b>SW6</b>	Control Mode	Open loop control	Closed loop control
<b>SW7</b>	Pulse Mode	CW/CCW (double pulse)	PUL/DIR (single pulse)
<b>SW8</b>	Pulse Filter Time	Yes (10ms)	No (1.5ms)

Remark:

- (1)CL57TE supports open-loop mode, which can be used when the encoder is damaged or judging whether the value of the position loop gain is wrong;
- (2) “Pulse Filter Time” means S-curve acceleration, to improve motion smoothness and high-speed start frequency in many circumstances. The Filter Time value must be set to the same for each CL57TE in multi-axis applications.

## 7. Typical Connection

A complete closed loop stepper system should include a stepper motor with encoder, CL57TE drive, power supply and controller (pulse generator). A typical connection is illustrated in figure 7.

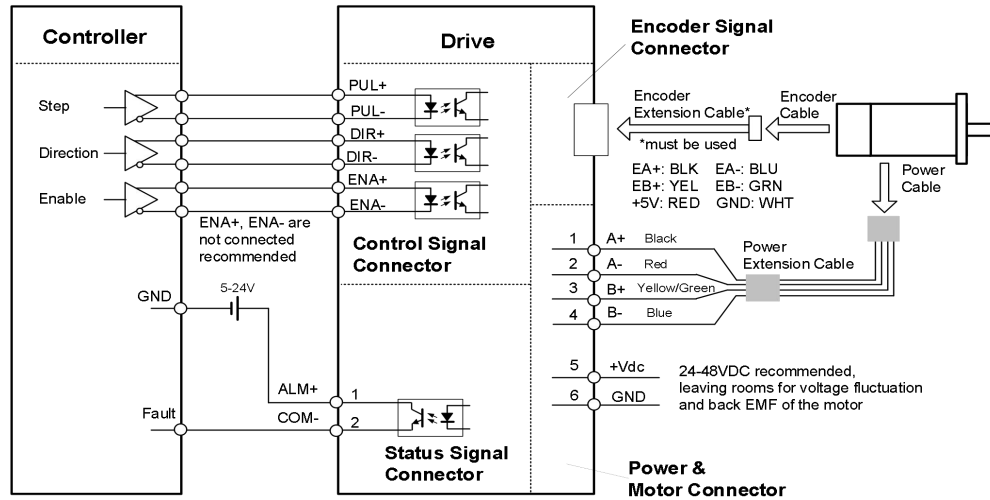

Figure 7: Typical connection

## 8. Sequence Chart of Control Signals

In order to avoid some fault operations and deviations, PUL, DIR and ENA should abide by some rules, shown as following diagram:

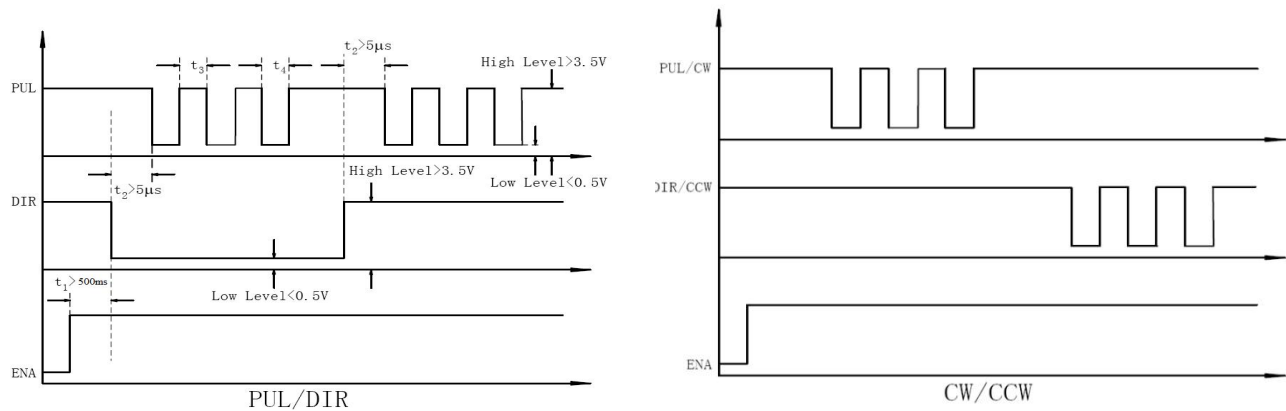

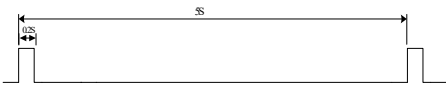
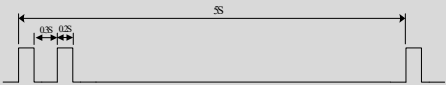



Figure 8: Sequence chart of control signals

### Remark:

- (1)  $t_1$ : ENA must be ahead of DIR by at least 500ms. Usually, ENA+ and ENA- are NC (no connected). See "Connector P1 Configurations" for more information.
- (2)  $t_2$ : DIR must be ahead of PUL effective edge by 5us to ensure correct direction.
- (3)  $t_3$ : Pulse width not less than 1us @ 5V, 2.5us @ 24V, these widths are based on a 50% duty cycle. If it is greater or less than 50%, the width time is required to be wider.

## 9. Fault Protections

To improve reliability, the drive incorporates some built-in protection features.

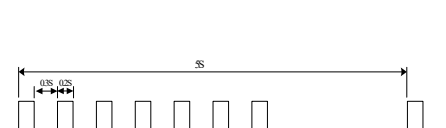
Blink time(s)	Sequence wave of red LED	Description	Trouble shooting
1		Over-current	Turn off the power immediately. a) Check wiring is short-circuited or not; b) Check motor is short-circuited or not.
2		Over-voltage	Turn off the power immediately. a) Check if the power voltage is higher than 90VDC
3		Chip error	Restart the power supply, if the drive is still alarm, please contact after-sale
4		Fail to lock motor shaft	a) The drive is not connected to a motor. b) If alarm is occurred when connect a motor, please check the motor wiring.
5		EEPROM error	Restart the power supply, if the drive is still alarm, please contact after-sale
6		Fail to auto tuning	Disable auto-tuning function by Stepperonline MotionStudio software
7		Position following error	a) The value of position following error is set too small. b) Motor torque is not enough, or motor speed is too high. c) Motor wiring error, check wiring
Always	-	PCB board is burned out	Contact after-sale a) Power supply connection is wrong

When above protections are active, the motor shaft will be free or the red LED blinks. Reset the drive by repowering it to make it function properly after removing above problems.

## 10. Software Configuration

The CL57TE is designed for simple setup and implementation. For most applications, no software configuration or tuning is needed especially when driving Stepperonline stepper motors with encoders (see Appendix A). If you want to do fine tuning or custom configurations such as micro-step, current percentage change..., you can use Stepperonline's free MotionStudio software to make the changes.

## 11. Accessories

If you plan to use the Stepperonline software, contact your supplier or Stepperonline to purchase the RS232 cable with part number [CABLE-PC-1](#) for connecting the CL57TE to a computer with Windows 7/8/10 installed. In the case of using USB to RS232 conversion, contact your supplier or Stepperonline for such a cable with part number [USB2.0-232](#) which has been verified working fine.



[CABLE-PC-1](#)

(RS232 tuning cable)



[USB2.0-232](#)

(USB to RS232 Conversion Cable)

## 12. Troubleshooting

If your drive does not operate properly, the first step is to identify whether the problem is electrical or mechanical in nature. The next step is to isolate the system component that is causing the problem. As part of this process you may have to disconnect the individual components that make up your system and verify that they operate independently. It is important to document each step in the troubleshooting process. You may need this documentation to refer back to at a later date, and these details will greatly assist our Technical Support staff in determining the problem should you need assistance.

Many of the problems that affect motion control systems can be traced to electrical noise, controller software errors, or mistake in wiring.

Symptoms	Possible Problems	Solutions
<b>Motor is not rotating</b>	No power	Connect power supply correctly
	Microstep resolution setting is wrong	Setting appropriate microstep
	Fault condition exists	Check wiring and restart power
	The drive is disabled	Drive restore factory setting, and keep ENA+, ENA- input signals unconnected.
<b>Wrong motor rotation direction</b>	The Direction signal level is reverse	Toggling the SW5 DIP switch
<b>The drive in fault</b>	Red light flashes once in a 5-second period	The motor coil may short circuit or exiting the wrong wiring
	Red light flashes twice in a 5-second period	The power supply exceeds Max. operation voltage

	Red light flashes 4-times in a 5-second period	Motor wiring poor contact, or motor wiring wrong
	Red light flashes 7-times in a 5-second period	If using Stepperonline's motor, maybe motor wiring poor contact; If using 3 <sup>rd</sup> motor, need to swap the wiring of motor phase A+ and phase A-
<b>Motor lost steps</b>	Control signal is too weak	Ensure the current of control signal is within 7-16mA
	Control signal is interfered	Don't tie the control signal cable with power cable together
	Control Signal timing wrong	ENA signal should ahead pulse signal 500ms
	Something wrong with motor coil	Check the motor is normal
<b>Motor stalls during acceleration</b>	Current setting is too small	Choose another power supply with lager power or increase the output current of drive
	Motor is undersized for the application	Choose another motor with higher torque
	Acceleration is set too high	Reduce the acceleration
	Power supply voltage too low	Choose another power supply with large voltage output
<b>Excessive motor &amp; drive heating</b>	Inadequate heat sinking / cooling	Refer to chapter 2.4
	Motor peak current setting is too high	Reduce the current value refer to motor datasheet
<b>Motor vibration when power on</b>	Position loop Kp is too high	Reduce the position loop Kp value
<b>Motor only one direction</b>	DIR inputs is burned	Check whether S1 is set to 5V, while the actual control signal is 24V
	Mismatched pulse types	Check if SW7 is set incorrectly

## 13. Warranty

### Twelve Month Warranty

Stepperonline Technology Co., Ltd. warrants its products against defects in materials and workmanship for a period of 12 months from shipment out of factory. During the warranty period, Stepperonline will either, at its option, repair or replace products which proved to be defective.

### Exclusions

The above warranty does not extend to any product damaged by reasons of improper or inadequate handlings by customer, improper or inadequate customer wirings, unauthorized modification or misuse, or operation beyond the electrical specifications of the product and/or operation beyond environmental specifications for the product.

### Obtaining Warranty Service

To obtain warranty service, please contact your seller to obtain a returned material authorization number (RMA) before returning product for service.

### Shipping Failed Products

If your product fail during the warranty period, please contact your seller for how and where to ship the failed product for warranty or repair services first, you can also e-mail customer service at [tech@Stepperonline.com](mailto:tech@Stepperonline.com) to obtain a returned material authorization number (RMA) before returning product for service. Please include a written description of the problem along with contact name and address.

## Appendix. Powering a Third-Party Motor with CL57TE

It is highly recommended to choose a Stepperonline closed stepper motor along with the CL57TE closed loop stepper drive, for getting the best system performance and easy setup.

For an OEM project if you can't find one on Appendix A meeting your requirements there, contact Stepperonline sales directly by emailing [sales@Stepperonline.com](mailto:sales@Stepperonline.com) or [sales@Stepperonlineusa.com](mailto:sales@Stepperonlineusa.com). Stepperonline carry's many other custom models and there may be one there which can satisfy your application need already.

In the case of powering a third party closed loop stepper motor, pay special attention as described below.

- Your stepper motor must be a 2-phase stepper motor
- Your stepper motor must be mounted with a quadrature rotary encoder with the resolution of 500-5,000 line (2,000- 20,000 CPR).
- When the CL57TE is first-time powered on after your stepper motor is connected, check the following possible causes if a position following error (see Section 9 above) happens.
  - Confirm both encoder and power cables are connected properly and tightly secured.
  - Power off the drive then swap the A+ and A- motor connections to the CL57TE drive. The reason is the definitions of your Motor A+ and A- are different from those marked on CL57TE motor connection pins (P3 of Figure 2).

If protection error is still seen after the above steps, contact your CL57TE drive supplier or Stepperonline technical support.