

| SPECIFICATION | VALUE |
|--------------------------------|----------------------|
| NO. of PHASES | 3 |
| NO. of POLES | 4 |
| RATED VOLTAGE(V) | 24 |
| RATED CURRENT(A) | 10.4±10% |
| RATED POWER(W) | 172 |
| RATED SPEED w/o GEARBOX(RPM) | 3500±10% |
| RATED TORQUE w/o GEARBOX(mN.m) | 470 |
| GEAR RATIO | 10 |
| EFFICIENCY | 95.00%REF |
| SENSOR | HALL SENSOR |
| INSULATION CLASS | CLASS B |
| INSULATION RESISTANCE | 100MΩ MIN @ 500VDC |
| DIELECTRIC STRENGTH TEST | 500VDC for 1 MINUTE |
| BEARING TYPE | NMB BALL BEARING, C3 |

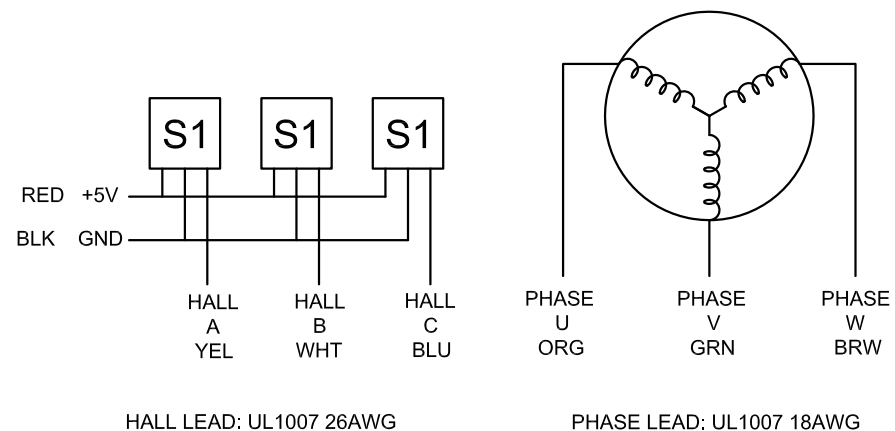

STEPPERONLINE®

| | | | |
|-------|-----------|--|----------|
| | APVD | | 6.4.2020 |
| | CHKD | | |
| 1.5:1 | DRN | | |
| SCALE | SIGNATURE | | DATE |

BRUSHLESS DC MOTOR

57BLR70-24-02-HG10